

2009

Reliability Assessment of a Power Grid with Customer Operated Chp Systems Using Monte Carlo Simulation

Lokesh Prakash Manohar
University of Massachusetts Amherst

Follow this and additional works at: <https://scholarworks.umass.edu/theses>

 Part of the [Power and Energy Commons](#)

Manohar, Lokesh Prakash, "Reliability Assessment of a Power Grid with Customer Operated Chp Systems Using Monte Carlo Simulation" (2009). *Masters Theses 1911 - February 2014*. 348.
Retrieved from <https://scholarworks.umass.edu/theses/348>

This thesis is brought to you for free and open access by ScholarWorks@UMass Amherst. It has been accepted for inclusion in Masters Theses 1911 - February 2014 by an authorized administrator of ScholarWorks@UMass Amherst. For more information, please contact scholarworks@library.umass.edu.

RELIABILITY ASSESSMENT OF A POWER GRID WITH
CUSTOMER OPERATED CHP SYSTEMS USING MONTE
CARLO SIMULATION

A Thesis Presented

by

LOKESH PRAKASH MANOHAR

Submitted to the Graduate School of the
University of Massachusetts Amherst in partial fulfillment
of the requirements for the degree of

MASTER OF SCIENCE IN MECHANICAL ENGINEERING

September 2009

RELIABILITY ASSESSMENT OF A POWER GRID WITH CUSTOMER OPERATED CHP SYSTEMS USING MONTE CARLO SIMULATION

A Thesis Presented

by

LOKESH PRAKASH MANOHAR

Approved as to style and content by:

Donald Fisher, Chair

Dragoljub Kosanovic, Member

Jon McGowan, Member

Donald Fisher, Department Head

Department of Mechanical and Industrial Engineering

ACKNOWLEDGMENTS

I would like to thank Dr. Beka Kosanovic for his mentoring, patience and support throughout my graduate program. Thanks to Dr. Donald Fisher and Dr. Jon G. McGowan for serving on my thesis committee.

I would like to acknowledge the help and assistance of all the fellow students and staff I have worked with in the Industrial Assessment Center. And thanks to my family for providing support and motivation.

ABSTRACT

RELIABILITY ASSESSMENT OF THE DISTRIBUTED NETWORK OF DISTRIBUTED GENERATION SYSTEMS USING MONTE CARLO SIMULATION

SEPTEMBER 2009

LOKESH PRAKASH MANOHAR, B.Tech., VELLORE INSTITUTE OF TECHNOLOGY
UNIVERSITY

M.S., UNIVERSITY OF MASSACHUSETTS AMHERST

Directed by: Dr. Dragoljub Kosanovic

This thesis presents a method for reliability assessment of a power grid with distributed generation providing support to the system. The distributed generation units considered for this assessment are Combined Heat and Power (CHP) units operated by individual customers at their site. CHP refers to the simultaneous generation of useful electric and thermal energy. CHP systems have received more attention recently due to their high overall efficiency combined with decrease in costs and increase in reliability. A composite system adequacy assessment, which includes the two main components of the power grid viz., Generation and Distribution, is done using Monte Carlo simulation. The State Duration Sampling approach is used to obtain the operating history of the generation and the distribution system components from which the reliability indices are calculated. The basic data and the topology used in the analysis are based on the Institution of Electrical and Electronics Engineers - Reliability Test System (IEEE-RTS) and distribution system for bus 2 of the IEEE-Reliability Busbar Test System (IEEE-RBTS). The reliability index Loss of

Energy Expectation (LOEE) is used to assess the overall system reliability and the index Average Energy Not Supplied (AENS) is used to assess the individual customer reliability. CHP reliability information was obtained from actual data for systems operating in New England and New York. The significance of the results obtained is discussed.

TABLE OF CONTENTS

	Page
ACKNOWLEDGMENTS	iii
ABSTRACT	iv
LIST OF TABLES	ix
LIST OF FIGURES	xii
CHAPTER	
1. INTRODUCTION	1
1.1 Background	1
1.2 Research Motivation	4
1.3 Research Objectives	5
1.4 Methodology	5
2. RELIABILITY ASSESSMENT	7
2.1 Reliability Assessment Methods	7
2.2 Reliability Indices	11
2.3 Assessment Techniques.....	14
2.3.1 Analytical Methods	15
2.3.2 Monte Carlo Simulations (MCS)	16
2.4 Reliability Test Systems and Data	20
3. SYSTEM MODELING	22
3.1 System Description	22
3.2 Load Modeling	25
3.3 Generation Modeling.....	27

3.4	Distribution System Modeling	29
3.5	CHP Generation Modeling.....	29
3.6	Reliability Assessment	32
3.6.1	Phase I – Before Installing CHP Units.....	33
3.6.2	Phase II – After Installing CHP Units.....	33
4.	DISTRIBUTION SYSTEM MODELING – BASIC TECHNIQUES.....	36
4.1	Evaluation Techniques	36
4.2	Evaluation of the distribution system for busbar 2 of IEEE-RBTS	41
4.3	Distribution system modeling and simulation.....	41
5.	CASE STUDIES & RESULTS – PART I.....	44
5.1	Common Aspects	44
5.2	Case Study 1	45
5.3	Case Study 2.....	47
5.4	Case Study 3.....	50
5.5	Case Study 4.....	56
5.6	Case Study 5.....	60
6.	CASE STUDY - 7.....	63
7.	CONCLUSION.....	70
7.1	Summary	70
7.2	Future Work	72
	APPENDICES	74
	A. DETAILS OF IEEE-RELIABILITY TEST SYSTEM.....	74
	B. DETAILS OF IEEE-RELIABILITY BUSBAR TEST SYSTEM.....	77

C. CHP UNIT RELIABILITY DATA.....	88
D. CALCULATION OF RELIABILITY PARAMETERS FOR THE DISTRIBUTION SYSTEM.....	89
E. RESULTS OF CASE STUDY 3	95
F. RESULTS OF CASE STUDY 4	102
REFERENCES	106

LIST OF TABLES

Table	Page
1.1 Typical Customer Unavailability Statistics	3
3.1: Customer Margin - Phase I	34
3.2: New Customer Margin – Phase II.....	35
4.1: Component Data for the System shown in Fig. 4.1	38
4.2: Load-Point Reliability Indices for the System of Fig. 4.1	38
4.3: Reliability Indices with Lateral Protection	39
4.4: Reliability Indices with Disconnects and Lateral Protection.....	40
4.5: Basic Reliability Indices for Load Points of Busbar 2 of IEEE-RBTS	42
5.1: Results of Case Study - 2.....	50
5.2: Details of Case Study 3 – Phase II- Experiment 1 to 5.....	51
5.3: Details of Case Study 3 – Phase II- Experiment 1 to 5.....	52
5.4: AENS and the Percentage Reliability for the 22 Customers in Case Study 3 Phase 1....	53
5.5: New LOEE Index, Percentage Reliability for Phase II Case Study 3	54
5.6: New AENS Index, Percentage Reliability for Customer 8 – Case Study 3.....	56
5.7: AENS and the Percentage Reliability for the 22 Customers in Phase I - Case Study 4..	58
5.8: New LOEE Index, Percentage Reliability for Phase II Case Study 4	59
5.9: New AENS Index, Percentage Reliability for Phase II Case Study 4	59
5.10: Percentage Improvement in Reliability for the Customers Studied in Phase II - Case Study 4	60
5.11: Reliability Parameters of the Distribution Line that Connects Customer 16 and Customer 22 to the busbar 2	61

5.12: Results of Experiment 1 - Case Study 5	61
5.13: Results of Experiment 2 - Case Study 5	62
6.1: Reliability Parameters for the 600 kW and 190kW CHP Units	65
6.2: Details of the Experiments - Case Study 7	67
6.3: Results for Experiments of Case Study 7	68
6.4: LOEE Results for Experiments of Case Study 7	68
A.1: IEEE – RTS Data for Centrally Controlled Generating Units	75
A.2: Weekly Peak Load in Percentage of Annual Peak.....	75
A.3: Daily Peak Load in Percent of Weekly Peak	76
A.4: Weekly Peak Load in Percentage of Annual Peak.....	76
B.1: Average and Peak Load of Customers at Various Load Points of the Distribution System.....	78
B.2: Reliability Parameters of Distribution System Components	78
C.1: Reliability Parameters for CHP Units	88
D.1: Calculation of Reliability Parameters for the Distribution Lines	89
E.1: Case Study 3 Experiment 1 Results - 8% of the Load Supplied by CHP units.....	95
E.2: Case Study 3 Experiment 2 Results – 15.5% of the Load Supplied by CHP units.....	96
E.3: Case Study 3 Experiment 3 Results - 25% of the Load Supplied by CHP units.....	97
E.4: Case Study 3 Experiment 4 Results – 48.4% of the Load Supplied by CHP units.....	98
E.5: Case Study 3 Experiment 5 Results – 73.3% of the Load Supplied by CHP units.....	99
E.6: Case Study 3 Experiment 6 Results – 95.4% of the Load Supplied by CHP units.....	100
E.7: Case Study 3 Experiment 7 Results – 100% of the Load Supplied by CHP units.....	101
F.1: Case Study 4 Experiment 1 Results - 5% of the Load Supplied by CHP units.....	102

F.2: Case Study 4 Experiment 2 Results - 15% of the Load Supplied by CHP units.....	103
F.3: Case Study 4 Experiment 3 Results - 25% of the Load Supplied by CHP units.....	104
F.4: Case Study 4 Experiment 4 Results - 50% of the Load Supplied by CHP units.....	105

LIST OF FIGURES

Figure	Page
2.1: Power System – Hierarchical Levels	11
2.2: Two-Stage Generation Model.....	15
2.3: Relationship between capacity, load and reserve	17
3.1: Flow Chart – Phase I.....	24
3.2: Flow Chart – Phase II	25
3.3: Hourly Load Curve for Customer at Load Point 2	26
3.4: Two-Stage Generation Model.....	27
3.5: System Capacity Curve for One Year.....	28
3.6: Sample Distribution Line Operational State Curve	29
3.7: Four-Stage System Model for CHP units	30
3.8: Sample CHP Unit Power Curve.....	31
4.1: Simple 3-Load Point Radial System.....	37
4.2: System of Fig. 4.1 with Lateral Protection	39
4.3: Network of Fig. 4.1 with Disconnects and Lateral Protection.....	40
4.4: Two-Stage Distribution Line Model.....	42
5.1: Load Curve for the Customer(s) that is Studied in Case Study 1	45
5.2: Monte Carlo Convergence of AENS for the Customer at Load Point 16 and Load Point 22.....	46
5.3: Monte Carlo Convergence of AENS for the Customer at Load Point 16 and Load Point 6	47

5.4: Monte Carlo Convergence of AENS for Customer 22 with No CHP Units at Customer Site	49
5.5: Comparison of Monte Carlo Convergence of AENS for Customer 22 with Two CHP Units and Three CHP Units	49
5.6: Monte Carlo Convergence of LOEE for Case Study 3 - Phase I.....	53
5.7: Percentage Reliability, LOEE - Case Study 3	55
5.8: Percentage Reliability, AENS, for Customer 8 – Case Study 3	56
5.8: Monte Carlo Convergence of LOEE for Case Study 4 Phase I.....	57
6.1: Hourly Electric Demand Profile	64
6.2: Hourly Thermal Load Profile	64
6.3: Optimal Electric Power Output of the 600kW CHP Units	65
6.4: Hourly Electric Demand Profile for Customer 22	66
6.5: Hourly Thermal Load Profile for Customer 22	66
6.6: Optimal Electric Power Output of the 190 kW CHP Units	67
A.1: IEEE – Reliability Test System	74
B.1: Distribution System of Busbar 2 - IEEE–Reliability Busbar Test System	77
B.2: Hourly Load Profile of Customer 1	79
B.3: Hourly Load Profile of Customer 2	79
B.4: Hourly Load Profile of Customer 3	80
B.5: Hourly Load Profile of Customer 4	80
B.6: Hourly Load Profile of Customer 5	80
B.7: Hourly Load Profile of Customer 6	81
B.8: Hourly Load Profile of Customer 7	81

B.9: Hourly Load Profile of Customer 8	81
B.10: Hourly Load Profile of Customer 9	82
B.11: Hourly Load Profile of Customer 10	82
B.12: Hourly Load Profile of Customer 11	82
B.13: Hourly Load Profile of Customer 12	83
B.14: Hourly Load Profile of Customer 13	83
B.15: Hourly Load Profile of Customer 14	83
B.16: Hourly Load Profile of Customer 15	84
B.17: Hourly Load Profile of Customer 16	84
B.18: Hourly Load Profile of Customer 17	84
B.19: Hourly Load Profile of Customer 18	85
B.20: Hourly Load Profile of Customer 19	85
B.21: Hourly Load Profile of Customer 20	85
B.22: Hourly Load Profile of Customer 21	86
B.23: Hourly Load Profile of Customer 22	86
B.24: Hourly Load Profile for the Distribution System at Bus 2.....	87

CHAPTER 1

INTRODUCTION

1.1 Background

For many years electric distribution systems were designed and used only to deliver electrical energy to customers; no generation was present on the distribution systems or on the customer side of the meter [1]. However, due to major changes in the power markets and improvements in technology, generation capacities are increasingly being added to distribution systems of power grid. These systems utilize both conventional and unconventional sources of energy. Such systems may be operated by the customer or the utility itself. The process of generating electricity through systems that are located on the distribution network or at the customer site is known as Distributed Generation. The following may be cited as important reasons for the increased interest in DG systems [2]:

- availability of modular generating plant
- ease of finding sites for smaller generators
- deregulation or competition policy
- diversification of energy sources
- national power requirement
- short construction times and lower capital costs of smaller plants
- generation may be sited closer to the load, which may reduce transmission costs

Also, the liberalization of energy markets and the saturation of existing networks due to continuous growth in demand have provided a push for distributed generation [3]. An

Electric Power Research Institute (EPRI) study recently concluded that by 2010, 25% of all

new generation would be distributed [4]. In a distributed generation system, the generator may be operated by the utility or by the customer. In both the cases the operation of a DG unit may be considered random. However, in some cases the operation of a customer operated DG unit, though random, depends on the customer load. This is especially true in the case of a customer operated CHP units.

CHP stands for Combined Heat and Power. CHP refers to a subsection of DG units that simultaneously generate usable electric energy as well as thermal energy. It is also known as cogeneration. CHP units are primarily operated by customers that have simultaneous need for both thermal energy and electric energy. By installing a CHP system designed to meet the thermal and electrical base loads of a facility, CHP can greatly increase the facility's operational efficiency and decrease energy costs. At the same time, CHP reduces the emission of greenhouse gases, which contribute to global climate change. More about CHP systems will be discussed in Chapters 3 and 6.

With rapid increase in demand and load on the existing networks distribution generation is growing fast. As the distribution generation systems became widespread several issues including technology, economics and reliability need to be addressed. Reliability has been an important system issue and it has been incumbent on power system managers, designers, planners and operators to ensure that customers receive adequate and secure supplies within reasonable economic constraints. The primary aim of reliability studies has been to maximize the benefits to the society and reduce overall costs. Historically, reliability has been assessed using deterministic criteria, techniques and indices. Analytical formulations have been used to evaluate the reliability of power system. However the operation of the distribution and the transmission networks, owing to varying customer loads

and random power flows, are stochastic in nature. This led to the evolution of reliability evaluation techniques using stochastic techniques. Stochastic techniques involve evaluating reliability using simulation methods, such as Monte Carlo simulation. Section 2.3 discusses the analytical and stochastic reliability evaluation techniques and the differences between the two.

The reliability evaluation of a power grid is a complex process. It requires a large amount of computer processing memory and time. Thus when the purpose of a study is to evaluate reliability of a particular subsystem it may not be of worth to model the entire system. Thus in order to simplify reliability evaluation process a power grid can be broken up into three levels viz., generation level, composite level (generation and transmission), and distribution system level. Studies can be conducted independently for each level to address various issues which may be specific to that level. Also studies performed at individual levels can be combined to evaluate the overall system reliability. Of the three levels, the distribution systems have received considerably less of the attention devoted to reliability modeling and evaluation [4]. One of the reasons is that the distribution system is relatively cheap and outages have a much localized effect. However, customer failure statistics of most utilities shows that the distribution system makes the greatest individual contribution to the unavailability of supply to a customer. This is illustrated in Table 1.1.

Table 1.1 Typical Customer Unavailability Statistics

Contributor	Average unavailability per	
	minutes	%
Generation/Trans	0.5	0.5
132 kV	2.3	2.4
66 kV and 33 kV	8.0	8.3
Distribution	86.0	88.8

1.2 Research Motivation

As outlined in the previous section, the reliability assessment of distribution networks has received considerably less attention. However, statistics such as that in Table 1.1 emphasize the need to be concerned with the reliability evaluation of distribution networks. Thus the primary purpose of this thesis is to demonstrate a method for reliability evaluation of distribution systems involving CHP generation systems.

The increase in demand for electricity has led to saturation of existing electricity networks, congestion at network nodes and loss of energy experienced by the customers. While capacity addition by the utility is a traditional and common approach to address this problem, DG units, especially CHP units are being increasingly preferred due to their higher efficiency and faster implementation. However, at the same time, the reliability of CHP units is a concern. Individual CHP units are known to have poor reliability when compared to utility operated electricity generation units. In this light, it is necessary to evaluate and compare alternatives that are faster to implement, operationally more flexible in nature and, above all, more reliable.

Though CHP generation units have relatively poor reliability, their operation at a customer site has been found to improve the reliability of power supply to that customer. The adequacy assessment for power systems has been studied considerably in the literatures [5] and [6] and the adequacy assessment for distributed generation systems, with random input into the system, has been performed in [7] to find the Annual Unsupplied Load (AUL). However, the analyses presented in this thesis takes into consideration the measured real-time operating characteristics of individual customers and CHP units. Further, the analysis includes the effects of generation components as well as the distribution system which is the

major contributor to unreliability (the transmission components were considered to be 100% reliable).

1.3 Research Objectives

This thesis attempts to answer the following questions.

1) How can the distribution system of a power grid, with CHP units at various load points, be modeled realistically for the purpose of reliability assessment?

2) What is the quantitative effect to the overall system reliability and the individual customer reliability due to the CHP units operating at various customer load points?

3) What is the optimum location that a customer operated CHP system shall be installed in a distribution system?

1.4 Methodology

This study takes a stochastic approach to reliability evaluation. Monte Carlo simulation method is used to generate an operating history of various components of the power system based on the measured parameters of the components. The two main parameters are Mean Time To Failure (MTTF) and Mean Time To Repair (MTTR). The operating profiles of the components of the system, including the customer load profile, are superimposed to obtain an operation profile of the entire system from which the reliability indices are evaluated. The difference between the reliability indices obtained before and after the implementation of CHP units can serve as a guide to quantitatively understand the significance of the difference made by CHP units to the existing system. Thus, the analysis is done in two phases. In the first phase, the adequacy assessment is performed on the system with the system power represented only by the power generated by the utility controlled

generation station. In the second phase, CHP units operating at various customer sites are included in the analysis. The methodology is elaborated in chapter 3 and 4.

For the purpose of analysis the Institution of Electrical and Electronics Engineers - Reliability Test System (IEEE RTS) and the IEEE-Reliability Test Busbar System (IEEE-RBTS) are used, as they represent a standardized model to enable different studies, which can then be validated by other results obtained from the systems. The unavailability of real data for system available capacity, reliability indices of various components of a power grid are also a driving factors in choosing the IEEE- Reliability Busbar Test System as the base system model for this analysis. Electric load profiles were also obtained from various customers, to enable realistic analysis of the system.

CHAPTER 2

RELIABILITY ASSESSMENT

Power systems have evolved over decades. Their primary emphasis has been on providing a reliable and economic supply of electrical energy to their customers. Spare and redundant capacities are inbuilt in order to ensure adequate and acceptable continuity of supply in the event of failures or forced outage of the plants, and the removal of facilities for regular schedule maintenance. Due to the improvements in distributed generation technologies a significant amount of spare capacities are also being added on the customer sites. Distributed generation systems ensure adequate and acceptable continuity of supply in the event of failures in the generation, distribution and/or transmission systems [7]. The degree of redundancy has had to be commensurate with the requirement that the supply should be as economic as possible. It is necessary that maximum reliability is met within the set economic constraints. This optimization problem, which is to maximize reliability within given economic constraints has been widely recognized and understood.

2.1 Reliability Assessment Methods

Various methods have been developed to solve the aforementioned optimization problem. The methods can be broadly classified as: 1. Deterministic, 2. Probabilistic or Stochastic.

The typical criteria that are used by deterministic methods to evaluate the reliability of systems are:

1. Planning generation capacity – installed capacity equals maximum demand plus a fixed percentage of the expected maximum demand.

2. Operating capacity – spinning capacity equals expected load demand plus a reserve equal to one or more largest units.
3. Planning network capacity – construct a minimum number of circuits to a load group (generally known as an (n-1)(n-2) criterion depending on the amount of redundancy), the minimum number being dependent on the maximum demand of the group.

The deterministic methods are easy to use for simple systems but they do not and cannot account for the probabilistic or stochastic nature of system behavior such as frequency, duration and amount of failures.

In order to model and simulate the stochastic nature of the components of power systems probabilistic methods were developed. Also the general complexities of the power systems, which includes the large size of the systems, random nature of operation of the components, need to simulate variations arising due to weather conditions, etc, has played a major role in advancing reliability studies using probabilistic methods. Typical probabilistic aspects (as against the deterministic criteria mentioned above) are:

1. Forced outage rates of generating units are known to be a function of unit size and type and therefore a fixed percentage reserve cannot ensure a consistent risk.
2. The failure rate of an overhead line is a function of the length, design, location, and environment and therefore a consistent risk of supply interruption cannot be ensured by constructing a minimum number of circuits.

3. All planning and operating decisions are based on load forecasting techniques. These techniques cannot predict loads precisely and uncertainties exist in the forecasts.

Some probabilistic measures that are generally evaluated include:

1. system availability
2. estimated unsupplied energy
3. number of failure incidents
4. number of hours of interruption
5. excursions beyond set voltage limits
6. excursions beyond set frequency limits

The above measures

1. identify weak area needing reinforcement or modifications
2. establish chronological trends in reliability performance
3. establish existing indices which serve as a guide for acceptable values in future reliability assessments
4. enable previous predictions to be compared with actual operating experience
5. monitor the response to system design changes

At this point, it is also necessary to understand the difference between absolute and relative measures. Absolute measures are useful in evaluating past performance. However, a high degree of confidence cannot be placed on absolute measures when they are used to predict future performance. On the other hand, relative measures are easier to interpret since the percentage improvement of a certain measure can be used to evaluate the before-and-after conditions. The indices used for reliability evaluation in this thesis are relative in that the

measures are evaluated and compared before and after the installation of CHP units at customer sites.

Power system reliability assessment can be divided into two basic concepts viz. system adequacy and system security. The concept of adequacy is generally considered to be the existence of sufficient facilities within the system to satisfy the customer demand. These facilities include those necessary to generate sufficient energy and the associated transmission and distribution networks required to transport the energy to the actual consumer load points. Adequacy thus is considered to be associated with static conditions which do not include system disturbances.

Security, on the other hand, is considered to relate to the ability of the system to respond to disturbances arising within that system. Security is therefore associated with the response of the system to whatever disturbances they are subjected. These are considered to include conditions local and widespread effects and the loss of major generation and transmission facilities. The security concept relates to the transient behavior of systems as they depart from one state and enter another state. The techniques presented in this thesis are concerned with adequacy assessment.

Modern power systems are immensely complex. Hence, in order to simplify various analyses that are performed on power systems, they are usually broken up into subsystems as shown in Figure 2.1. The analysis presented in this thesis is a hierarchical level 3 (HL 3). It involves modeling and simulation of generation and distribution facilities. The transmission facilities are considered to be 100% reliable.

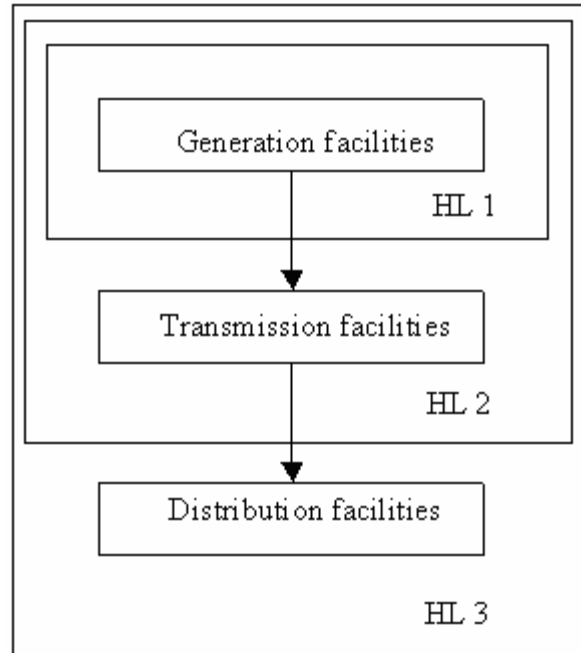

Figure 2.1: Power System – Hierarchical Levels

2.2 Reliability Indices

The adequacy assessment of a power system involves evaluation of certain measures at one or more of the hierarchical levels. Each measure is concerned with a single reliability aspect or a combination of certain reliability aspects. Such aspects are system availability, estimated unsupplied energy, number of incidents, number of hours of interruption, etc. For example, some of the reliability measures are:

1. SAIFI – System Average Interruption Frequency Index

$$\text{SAIFI} = \frac{\text{total number of customer interruptions}}{\text{total number of customers served}}$$

2. SAIDI – System Average Interruption Duration Index

$$\text{SAIDI} = \frac{\text{sum of customer interruption durations}}{\text{total number of customers}}$$

3. CAIFI – Customer Average Interruption Frequency Index

$$CAIFI = \frac{\text{total number of customer interruptions}}{\text{total number of customers affected}}$$

4. CAIDI – Customer Average Interruption Duration Index

$$CAIDI = \frac{\text{sum of customer interruption durations}}{\text{total number of customer interruptions}}$$

5. ASAI – Average Service Availability Index

$$ASAI = \frac{\text{customer hours of available service}}{\text{customer hours demanded}}$$

The measures that are evaluated in this thesis are the LOEE (MWh/yr) and the AENS (MWh/yr/customer) which are described below.

The Loss of Energy Expectation (LOEE) index incorporates the severity of deficiencies in addition to their duration, and therefore the impact of energy shortfalls as well as their likelihood is evaluated. It is therefore often used for situations in which alternative energy replacement sources are being considered. This index is evaluated at the overall system level. Conceptually this index (LOEE) can be explained using the following mathematical expression.

$$LOEE = \sum_{i \in S} 8760 C_i p_i \quad (2.1)$$

Where i denotes the state of the system (whether the system is operational, has been shut down by the user or has failed), C_i is the loss of load for system state i , p_i is the probability of system state i , and S is the set of all system states associated with the loss of load.

The Average Energy Not Supplied (AENS) index is used to evaluate reliability at the customer level (MWh/customer/year) is used. The choice of the index to be used for distribution system reliability is made based on the data available for evaluation. Since data

for energy outage frequencies and durations was not available but load profiles for different customers within the system were, enabling the calculation of the total loss of energy over the year, the index AENS was used. Conceptually this index (AENS) can be explained using the following mathematical expression.

$$AENS = \frac{ENS}{\sum_{i \in R} N_i} \quad (2.2)$$

Where i denotes the point at which load is experienced (a load bus), ENS is the total Energy Not Supplied, N_i is the number of customers at load point i , and R is the set of load points in the system. The equations for calculating the above indices using probabilistic methods (Monte Carlo Simulation) are given in the Chapter 3.

During the initial years a number of techniques were developed for reliability assessment. However, until 1979, there was no general agreement of either the system or the data that should be used to demonstrate or test proposed techniques. Consequently it was not easy, and often impossible to compare and/or substantiate the results obtained from various proposed methods. The IEEE Subcommittee recognized this problem on the Application of Probability Methods (APM), which, in 1979, published the IEEE-Reliability Test System (IEEE – RTS) [9]. This is a reasonably comprehensive system containing generation data, transmission data and load data. It is intended to provide a consistent and generally acceptable set of data that can be used in generation system reliability evaluation. This has enabled results obtained by different people using different methods to be compared. The IEEE - RTS centre only on the data and results for the generation and transmission system: it does not include any information relating to distribution system. Thus, as an extension to IEEE - RTS, the IEEE - Reliability Busbar Test System (IEEE - RBTS) was published in 1991 [10]. The IEEE – RBTS outlines the topography of the distribution systems at busbar 2

and busbar 4 of the IEEE – RTS. It includes the main elements found in practical systems and thus serves as a common platform for evaluation of distribution systems.

Data collection and reliability evaluation should evolve together as both are very important aspects of system performance evaluation and one cannot be completely and realistically accomplished without the other. Data needs to be collected for two fundamental reasons; assessment of past performance and/or prediction of future system performance. In order to predict, it is essential to transform past experience into the required future prediction. Collection of data is therefore essential as it forms the input to relevant reliability models, techniques and equations. The data must be sufficiently comprehensive to ensure that the methods can be applied but restrictive enough to ensure that unnecessary data is not collected.

2.3 Assessment Techniques

In this section the actual methodology used in the two reliability assessment techniques, viz., analytical methods and stochastic methods, are discussed. Analytical techniques represent the system by analytical models and evaluate the indices from these models using mathematical solutions. Stochastic simulation involves real time simulation of the systems using the Monte Carlo simulation method. The stochastic simulation can be further classified as random or sequential. The random approach simulates the basic intervals of the system lifetime by choosing intervals randomly. The sequential approach simulates the basic intervals in chronological order. The analysis presented in this thesis involves Monte Carlo Simulation using the sequential approach.

2.3.1 Analytical Methods

Many analytical methods are based on the Calabrese approach [13] in which a Capacity Outage Probability Table (COPT) represents the generation model. The method is explained using an example of a two-stage model for generation as shown in Figure 2.2.

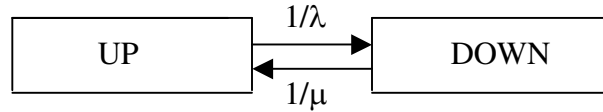

Figure 2.2: Two-Stage Generation Model

Where λ = Expected failure rate ($1/\lambda$ is the Mean Time to Failure - MTTF) and

μ = Expected repair rate ($1/\mu$ is the Mean Time to Repair - MTTR)

The basic generating unit parameter used in adequacy evaluation is the unavailability, also known as the forced outage rate (FOR). The availability (A) and unavailability (U) are given by equations (2.3) and (2.4) respectively.

$$Unavailability(FOR)=U=\frac{\lambda}{\lambda+\mu}=\frac{MTTR}{MTTR+MTTF}=\frac{\sum DownTime}{\sum DownTime+\sum UpTime} \quad (2.3)$$

$$Availability=A=\frac{\mu}{\lambda+\mu}=\frac{MTTF}{MTTR+MTTF}=\frac{\sum UpTime}{\sum DownTime+\sum UpTime} \quad (2.4)$$

A capacity outage probability table (COPT) is an array of the capacity levels and their probabilities of existence. The analytical method uses the recursive algorithm to form the COPT. The recursive algorithm for adding two state generating units is given by equation (2.5). This equation shows the cumulative probability of a certain capacity outage of X MW calculated after one unit of capacity C MW, with a forced outage rate U, is added

$$P(X)=(1-U)P'(X)+(U)P'(X-C) \quad (2.5)$$

Where $P'(X)$ and $P(X)$ are the cumulative probabilities of the capacity outage state of X MW before and after the unit of MW rating C is added. The generation model is then superimposed on the load model to calculate the desirable reliability index. The load model used depends upon the required reliability index. One common load model represents each day by the daily peak load, while another one represents the load using the individual hourly load values. If the daily peak loads are arranged in descending order, the formed cumulative load model is called the daily peak load variation curve. Arranging the hourly load values in descending order creates the load duration curve. This analysis uses the hourly peak load values for reliability index evaluation (load duration curve).

The relationship between load, capacity and reserve is shown in Figure 2.3. When the load duration curve is used, the shaded area E_k represents the energy that cannot be supplied in a capacity outage state k . The probable energy curtailed in this case is $p_k E_k$, where p_k is the individual probability of the capacity outage state k . The Loss of Energy Expectation is then given by

$$LOEE = \sum_{k=1}^n p_k E_k \quad (2.6)$$

Where, n is the total number of capacity outage states.

The LOEE can be normalized using the total energy E under the load duration curve as shown in equation (2.7).

$$LOEE = \sum_{k=1}^n \frac{p_k E_k}{E} \quad (2.7)$$

2.3.2 Monte Carlo Simulations (MCS)

The basic principle of MCS can be described as follows. The behavior pattern of n identical real systems operating in real time will all be different to varying degrees, including

the number of failures, the time between failures, the restoration times, etc. This is due to the random nature of processes involved. Therefore the behavior of a particular system could follow any of these behavior patterns.

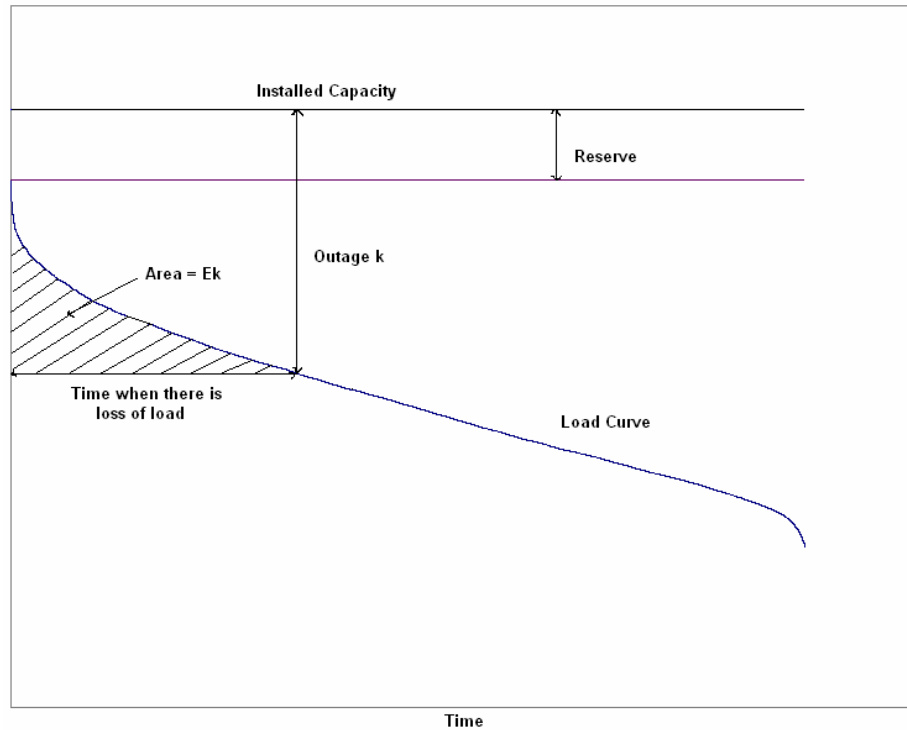

Figure 2.3: Relationship between capacity, load and reserve

The simulation process is intended to examine and predict these real time behavioral patterns in simulated time, to estimate the expected or average values of the various reliability parameters, and to obtain the probability distribution of each of the parameters.

Some of the important aspects of Monte Carlo simulation are:

1. A large number of experiments are required to be performed in order to obtain a satisfactory result
2. The convergence toward the true value is obtained by performing a large number of experiments, though, the convergence may be slow.
3. The sequence of outcomes of experiments may be different if different set

of random numbers are generated. However, as long as the probability distribution function that defines the generation of random number remains the same, the true value to which the experiments converge is also the same.

The Monte Carlo simulation approach requires a large amount of computing time and storage in order to develop a good system model. However, the simulation technique is easy to apply and can be used to solve not only simple problems but also problems where direct analytical solutions may not exist.

One of the issues with Monte Carlo simulation method is the statistical noise. The basic idea of Monte Carlo simulation is to simulate the random transitioning of components from one state to another over the course of the experiment and to calculate the expectation value of the quantity of our interest in each experiment. Also, in the present thesis the customer loads for consecutive iterations are randomly varied within 5% of the observed using Monte Carlo method. It shall be noted that we start with a small set of information (generation system details, distribution system details, customer load details and CHP unit's details) and conduct a large number of experiments (iterations) using the random values generated by the Monte Carlo method. While this is the primary advantage of the Monte Carlo method, it is also the disadvantage in that statistical errors are involved in the calculations. The best way to minimize statistical noise is to estimate as many expectations of the quantity as possible by running a large number of experiments [17].

Simulation Process

Random number generation is the first step of a Monte Carlo simulation process.

Usually a random number generator is used to generate uniformly distributed random number

U in the range 0 to 1. The present thesis employs the inbuilt function rand() in C++ to generate the random numbers. The random numbers thus generated are converted into values representing a non-uniform probability distribution. Reliability studies of individual power system components have shown that the basic reliability indices of the components follow exponential distribution. In other words, the transition rate of a component from a state to another is exponential. Thus, say, λ is the Mean Time To Failure (MTTF) of a component in the system, the amount of time before the component fails (UP state) is given by equation (2.8).

$$T_{UP} = -\frac{1}{\lambda} \ln U \quad (2.8)$$

After the component has transitioned to the DOWN state it is necessary to calculate the amount of time that the component shall reside in the DOWN state or the time remaining before it shall transition to the UP state. Equation (2.9) which is similar to equation (2.8) is used for this. The only difference is that the parameter Mean Time To Repair (MTTR), r is used in the equation.

$$T_{DOWN} = -\frac{1}{r} \ln U \quad (2.9)$$

Thus, the random number generation process is used for simulating and estimating the state durations of each component in the system. Hence this method is known as state duration sampling approach. The method is used to estimate the state durations or state history of generation units, distribution system components and CHP generation units. The system state history of each component in the system is superimposed along with the load curve of the customers to determine the reliability indices, the LOEE and AENS. This is dealt in greater detail in Chapter 3.

2.4 Reliability Test Systems and Data

IEEE – RTS

Meaningful reliability evaluation requires reasonable and acceptable data. These data are not always easy to obtain, and there is often a marked degree of uncertainty associated with the required input. Also an intended comparison between the results obtained from different reliability evaluation approaches can be made only if the approaches had used common power system configuration and basic reliability data. With these in mind, a reliability test system was developed in 1979, known as the IEEE Reliability Test System (RTS) [9]. The test system is a basic model that could be used to compare methods for reliability analysis of power systems. It includes generation and major transmission configuration and associated basic reliability indices, however, it does not include distribution system configuration. The total installed capacity of the IEEE - RTS is 3,405 MW. The maximum peak load of the system is 2,850 MW. Appendix A summarizes all the relevant details of the IEEE RTS.

IEEE - RBTS

The IEEE – RTS has proved to be a valuable and consistent source for reliability studies involving generation and transmission studies. In order to provide a similar test bench for comparison of reliability evaluation methods involving distribution systems, the IEEE Reliability Busbar Test System (RBTS) was developed in 1991 [10]. In IEEE – RBTS distribution network designs were provided for two busbars from IEEE – RTS, viz., bus 2 and bus 4. It contains peak load and average load information of the customers in the buses. It also contains the basic reliability data of various components in the distribution network.

For the purpose of this thesis, the distribution system at bus 2 is selected for reliability evaluation. There are 22 load points in the distribution system of bus 2. The peak load of bus 2 is 20 MW and the average load is 12.29 MW. Each load point is connected to the main bus via 11/0.415 kV transformers, 11 kV breaker, 11 kV overhead line, 33/11 kV transformer, 33 kV breaker, 33 kV overhead line, 138/33 kV transformer and 138 kV breaker in that order. The configuration of the distribution system, customer load, and the basic reliability data for the components are summarized in Appendix B.

In order to estimate the reliability indices accurately hourly customer load profile information is desirable. Although, this can be generated using the customer peak and average load data, the primary intention of this thesis is to evaluate reliability indices for real world customers. Hence, hourly load profiles were obtained from real world customers and from which 22 were chosen such that their average and peak loads match those given in IEEE - RBTS. The customer load profiles are shown in Table B.2 through Table B.23 of Appendix B. The sum of the customer load profiles gives the distribution system hourly load curve which is shown in Table B.1 of Appendix B.

CHAPTER 3

SYSTEM MODELING

3.1 System Description

Customers are supplied electricity via the distribution grid owned and controlled by certain utilities. This utility supplied power might not always be sufficient to meet the demand requirements of all the customers in its supply area. Some customers within the system can opt to install distributed generation units. This would mean that some of the customer load is invisible to the grid or the utility controlled substations when the DG units are in operation. However, when the DG units fail, the customers will rely on electric supply from the utility to meet their needs.

Combined Heat and Power (CHP) systems are the most commonly used Distributed Generation systems. The main difference between a CHP system and other DG technologies is that the CHP systems involve simultaneous generation of useful thermal and electric energy while other DG technologies involve generation of electricity only. A CHP system can have a total efficiency of over 80%, while the combination of electric energy obtained from a central power plant (with an efficiency of ~35%) and thermal energy obtained from an on-site boiler (with an efficiency of ~80%) has a total efficiency of approximately 50%. CHP systems are ideal for customers that have simultaneous electric and thermal load.

The CHP technologies usually consist of a heat engine that burns a fossil fuel producing thermal energy. Part of the thermal energy is converted to mechanical energy in a prime mover, such as a turbine or reciprocating engine which in turn powers a generator. The rest of the thermal energy or the waste heat from the prime mover is directly used for thermal

energy requirements of the customer. Such requirements may be process heating or space conditioning. Various CHP system technologies include reciprocating engine-generator system, steam boiler-turbine-generator system, gas turbine-generator systems, and fuel cells.

This chapter explains the method to model a power generation and distribution system, which is then used to evaluate the impact that the CHP units have on the utility controlled system and also on the reliability of power supply to the customers. For the purpose of this thesis, the generation and distribution system under consideration is modeled from IEEE - RTS and IEEE - RBTS. The details of the IEEE - RTS and the IEEE - RBTS are given in Appendix A and B, respectively, and the systems are explained in Chapter 5.

The impact of CHP units on the system can be evaluated by conducting reliability analysis before and after the implementation of CHP units in the system. Thus, the reliability assessment is done in two phases; in phase I the reliability of the overall system and power supply to the customer are evaluated without any customer controlled CHP units operational in the system and in phase II the reliability is evaluated for the scenario wherein customer controlled CHP units are operating in the system. Figure 3.1 and 3.2 represents the flow of data and the modeling process in phase I and phase II respectively. In the following sections, the modeling process is elaborated.

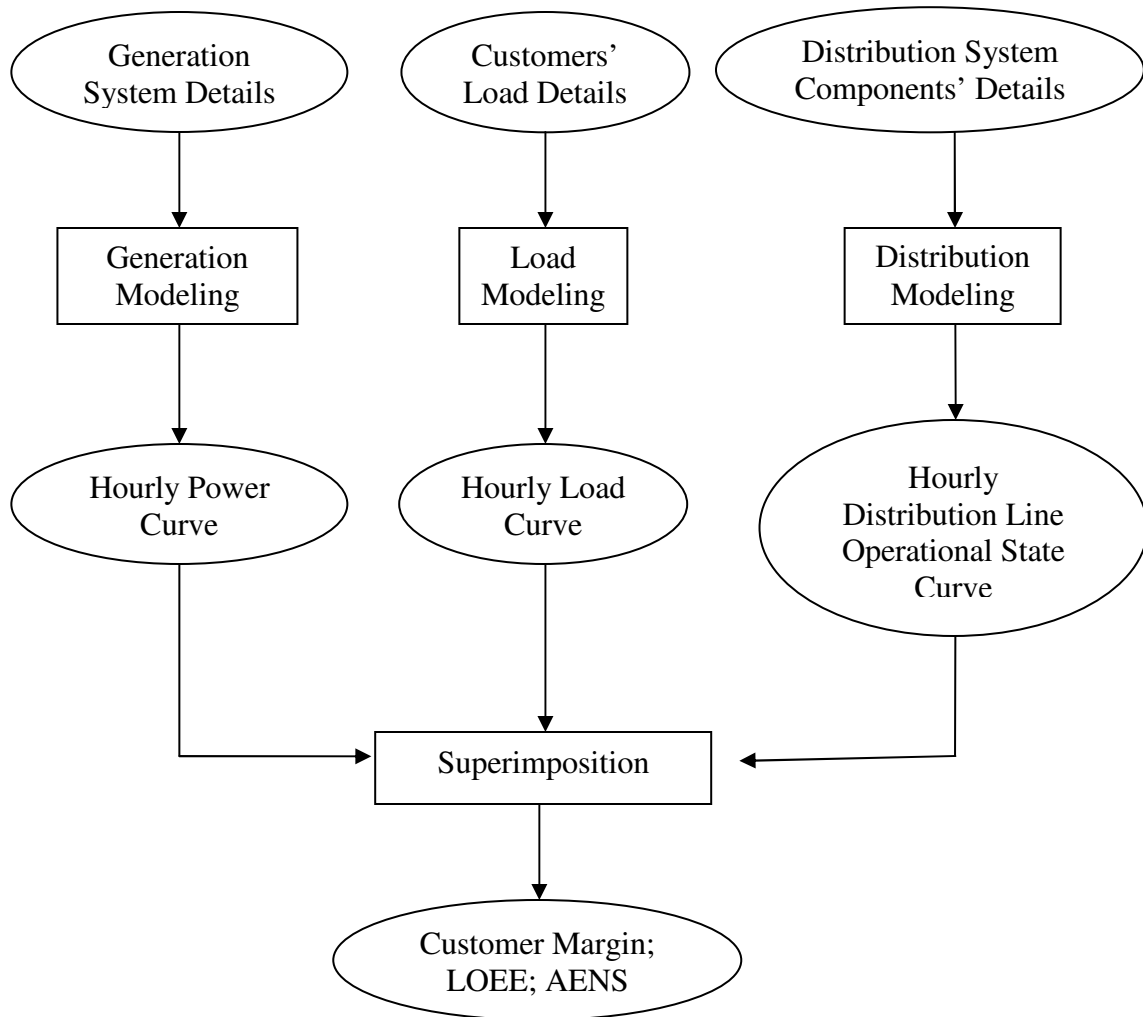

Figure 3.1: Flow Chart – Phase I

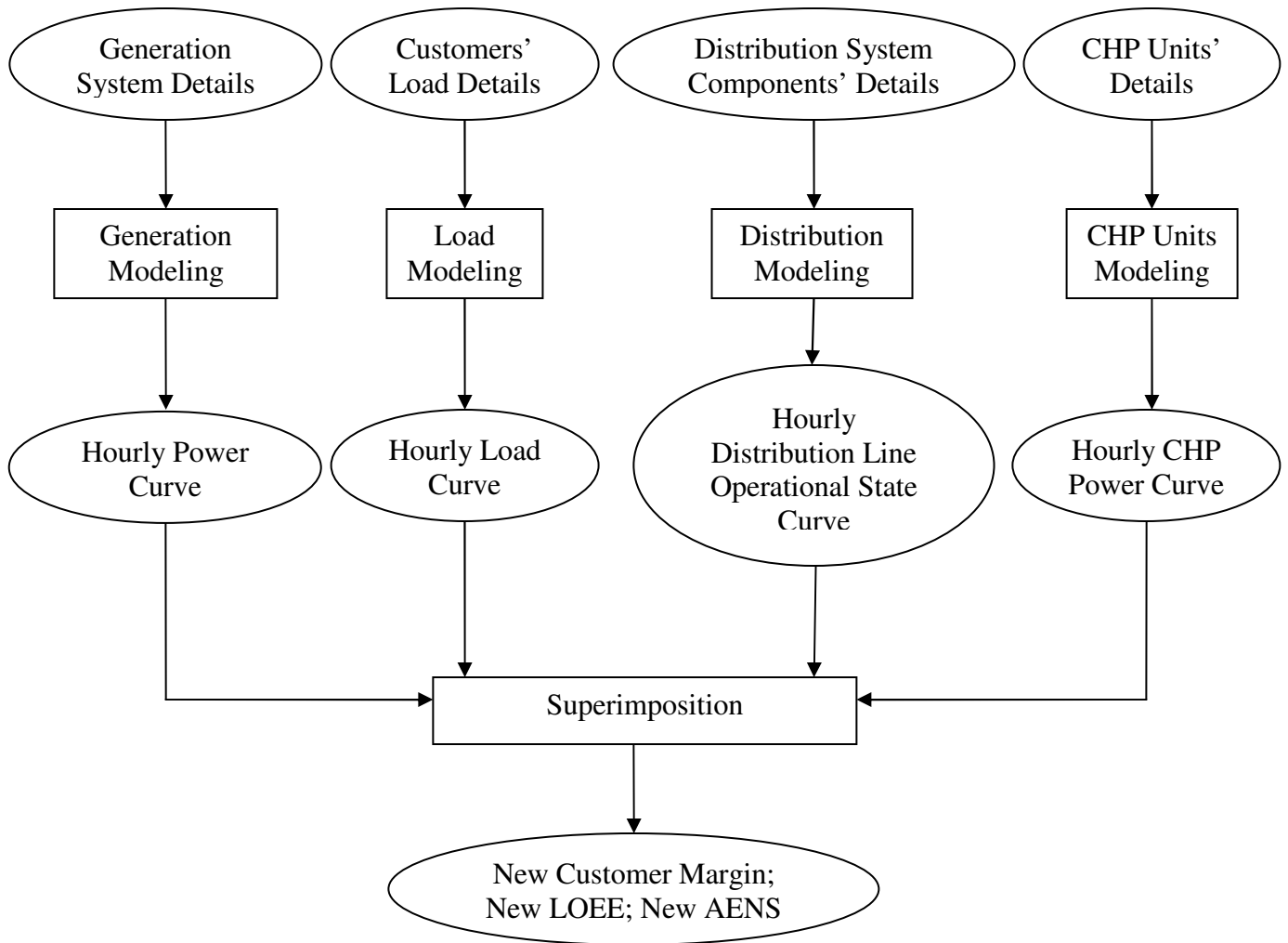

Figure 3.2: Flow Chart – Phase II

3.2 Load Modeling

The total load on the distribution system ($\text{Load}_{\text{system}}$) and individual customer load ($\text{Load}_{\text{customer}}$) for one year at least is required to conduct reliability test studies (one year's worth of load data can take into consideration seasonal variation in load and other irregularities.). A profile for the total hourly load on the distribution system is usually known to the utility for various load zones. This is a sum of all the customer loads on a particular

distribution system. The hourly load for any customer is also available, usually monitored by the customers themselves or the utility. A sample hourly load curve for one of the customers is shown in Figure 3.3. This customer is assumed to be connected to the load point 2 (LP – 2) of the busbar 2 of the IEEE-RBTS. The load profiles for all the 22 customers in the busbar 2 of the IEEE-RBTS are given in Table B.2 through Table B.23 of Appendix B.

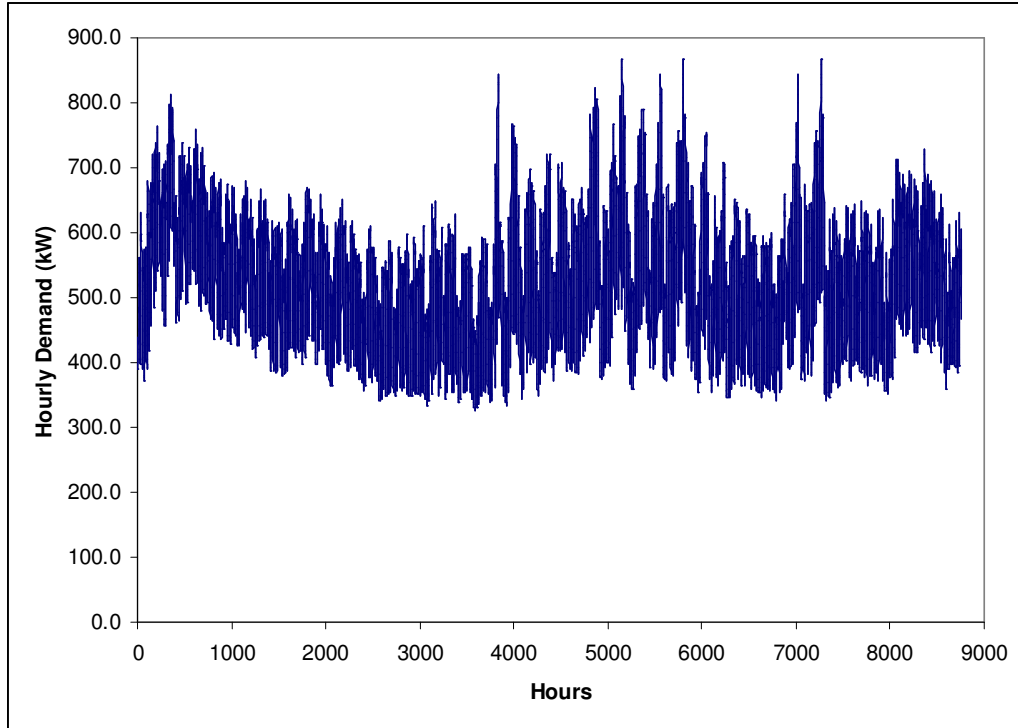

Figure 3.3: Hourly Load Curve for Customer at Load Point 2

For the purpose of this thesis several real time load data were obtained from a number of real world customers. From this pool of load profiles, 22 were chosen such that their peak load and average load are equal to the peak load and average load of the 22 load points in the busbar 2 of the IEEE-RBTS. These 22 load profiles are considered to be the load profile of the 22 load points and will be used for reliability assessment.

The load modeling involves generation of system load profile and customer load

profile such that for each iteration (or year) the load profiles vary randomly by up to 5% from the collected load data. The result of load modeling is the customer hourly load curve and the sum of all customer load curves gives the distribution system hourly load curve.

3.3 Generation Modeling

The utility controlled substation is supplied with power by many utility-owned centralized generating units (could be coal, hydro, nuclear, oil, natural gas etc.). The working parameters for these generating units can also be obtained from the utility (Mean Time To Failure, Mean Time To Repair, and Scheduled Outage Factor for each unit). The present analysis uses details obtained from IEEE-RTS. These parameters are used to simulate the operating history for the power system.

These units have varying operating cycles and can be modeled as two stage systems as shown in Figure 3.4 (same as Figure 2.3). The UP state indicates that the unit is in its operating state and the DOWN state implies that the unit is inoperable due to a failure or a scheduled shut down. The transition from one stage to another is determined using the parameters Mean Time to Failure (MTTF – from UP to DOWN) and Mean Time to Repair (MTTR – from DOWN to UP). To model this two-stage system, the State Duration Sampling approach explained in section 2.3 is used.

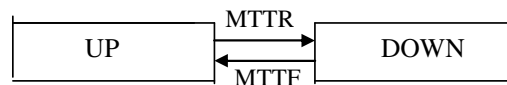

Figure 3.4: Two-Stage Generation Model

Given that the transition of generation units from one state to another follows exponential distribution, the duration that a unit resides in a particular state is given by equations (2.8) and equation (2.9). The generation modeling step essentially involves

generating random numbers that are exponentially distributed, using the Monte Carlo simulation. Each random number thus generated is used in equations (2.8) and (2.9). The result of this step is a system state profile, i.e., the state of the unit and the amount of time it resides in the state before transitioning to the next state. Now generating capacities are assigned to the unit based on the state. During the UP state a full generation capacity is assigned to the unit and during the DOWN state the generating capacity of the unit is assigned to be zero.

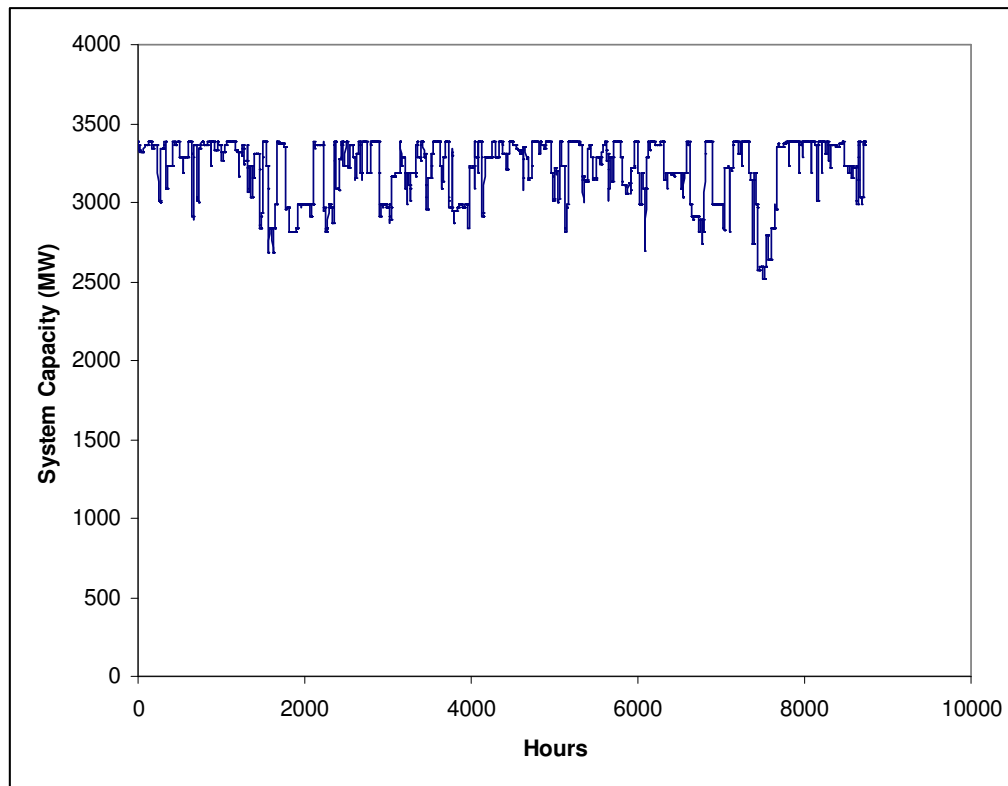

Figure 3.5: System Capacity Curve for One Year

The above process is repeated for all the units in the IEEE-RTS and summing up the assigned generating capacities for all the units results in the system power curve. The result of generation system modeling is the hourly power curve. A sample power curve for one year is shown in Figure 3.5.

3.4 Distribution System Modeling

One of the main objectives of this thesis is to demonstrate a method to realistically model the distribution system of a power grid for the purpose of reliability evaluation. Hence, the modeling of a distribution system is explained in greater detail in chapter 4. The result of the distribution system modeling step is the distribution line operational state curve. A sample distribution line operational state curve is shown in Figure 3.6. In the figure, the UP state is represented by 1 and the DOWN state is represented by 0.

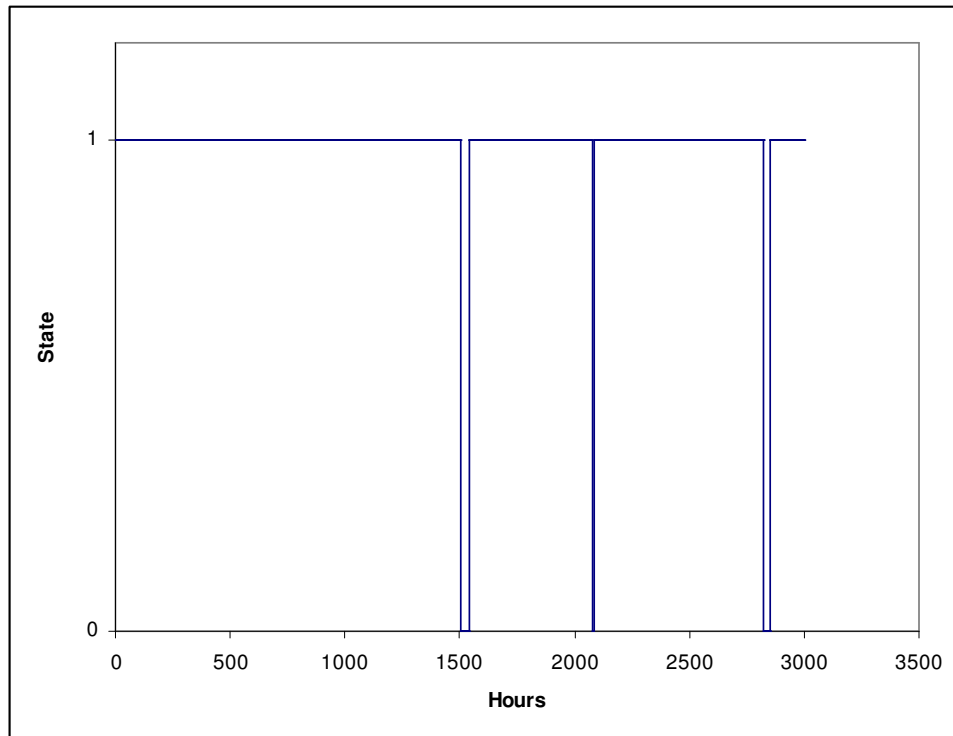

Figure 3.6: Sample Distribution Line Operational State Curve

3.5 CHP Generation Modeling

The CHP generation modeling step deals with two aspects. The first aspect is related to the modeling of the CHP generation units. The second aspect is related to the determination of the number, sizes and location of the CHP units at various customer sites.

The modeling of the CHP units is similar to the modeling of generation units that are operated by the utility, which is explained in section 3.3. The only difference is that the CHP units are modeled as four-stage systems, as shown in Figure 3.7, instead of the two-stage model that was used for utility operated generation units. It is assumed that at the beginning of the simulation, the CHP units are all in the UP state. The CHP unit can transition to the DOWN, DERATED or FAILED states from the UP state. The UP state indicates that the customer is operating the CHP unit at full generation capacity.

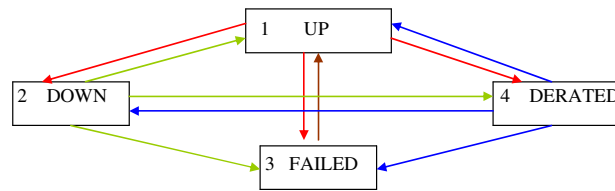

Figure 3.7: Four-Stage System Model for CHP units

The DOWN state is a “scheduled shut down” stage, i.e. the customer shuts down the CHP unit voluntarily. The DERATED stage indicates that the DG unit is operating at derated capacity, which is a certain percentage of the full generation capacity. The FAILED state indicates that the system has encountered an unscheduled shutdown. The transition from one state to another is determined by the basic reliability parameters: Mean Time To Failure, Mean Time To Repair and Schedule Outage Factor. The values of these parameters for the CHP units considered in this thesis are presented in Table C.1 of Appendix C. This information is based on a study conducted at the Northeast CHP application center at the University of Massachusetts Amherst [16]

The electric power generated by the CHP unit follows the load requirement of the customer. Hence there might be more than one derated state present, or there might be no derated state present at all. To model the four-stage system, the State Duration Sampling

approach explained in section 2.4.2 is used. However, when the system is in the operational state, the electricity it generates will depend upon the customer load at that time, i.e. it might be running at full or derated capacity. The result of CHP generation simulation is the CHP power curve a sample of which is shown in Figure 3.8.

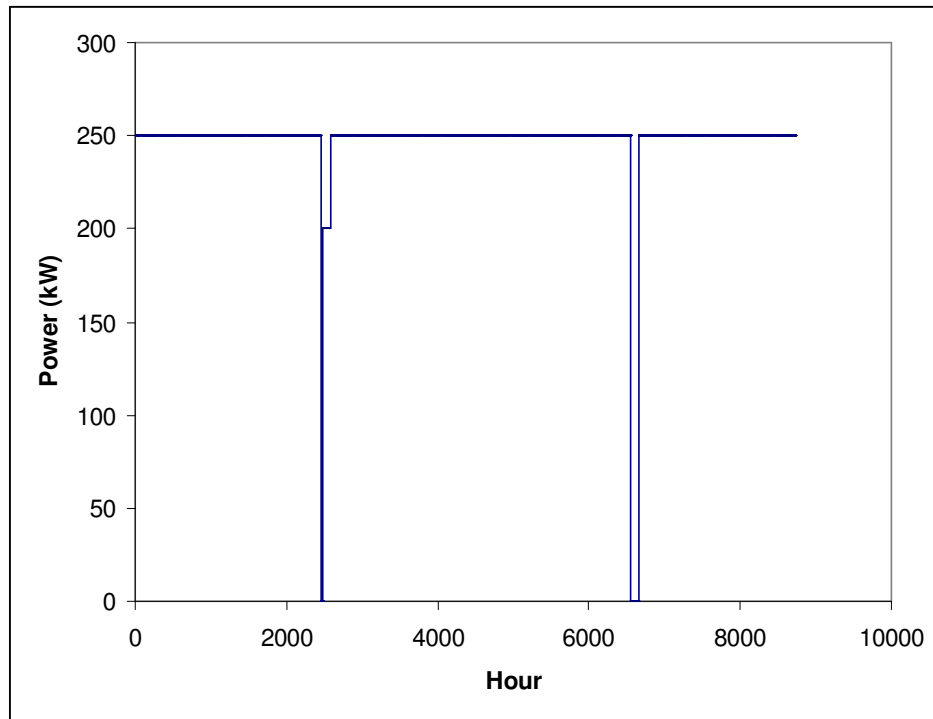

Figure 3.8: Sample CHP Unit Power Curve

In order to perform an effective evaluation of the contribution of CHP units to the system and customer reliability it is necessary to determine the number, sizes and the location of CHP units that shall be operated at various customer sites. An important conclusion of the work done by Tejal Kanitkar [14] is that the reliability of power supply to the customer is maximized when three CHP units operate at the customer site such that the combined capacity of the three CHP units is equal to the peak load of the customer. In the present thesis, this conclusion is first verified through a case study, and then extensively used in all the case studies.

The location of CHP units in the busbar 2 of the IEEE-RBTS is determined based on the following criteria. Consider the distribution system at the busbar 2 of the IEEE-RBTS. Given two customers with similar load profile, one nearest to the 33kV supply point (say, at load point 16) and the other farthest from the 33kV supply point (say at load point 22), it is first verified in case study 1 that the customer located farthest from the supply point experiences the least reliability in power supply. It is inferred that this is due to the presence of additional components in the distribution line that connects the farthest customer to the supply point. Thus for the assumption that CHP units do improve the reliability of power supply to the customers, it is expected that the magnitude of improvement would be the largest if the CHP units are located at the customer site that is farthest from the supply point. Selecting a customer that is located farthest from the supply point as a potential site for the operation of CHP units might offer the best case scenario for reliability evaluation.

Based on this criterion CHP units are considered to operate at load point 22 for case studies 1, 2, and 5. The second criterion is based on the purpose of the case study. In case studies 1 and 5 which involve comparing the improvement in reliability for two customers load point 22 and load point 16 become the obvious choices. Case studies 3 and 4 are mainly concerned with the evaluation of overall system reliability when CHP units constitute a certain percentage of the total load. For these two case studies the load points, where CHP units shall be operated, are selected such that the sum of their average loads is 5%, 15%, 25%, and 50% of the total system load. The purpose, methodology and results of the case studies are elaborated in Chapter 5 and 6.

3.6 Reliability Assessment

The reliability assessment basically involves superimposing the curves obtained in the

above modeling steps. To evaluate the impact of CHP units on the system the reliability assessment is done in two phases - (A) before installing CHP units and (B) after installing CHP units

3.6.1 Phase I – Before Installing CHP Units

In Phase I, the Customer Margin is determined by superimposing the hourly load curve, the hourly system power curve of the utility owned generation units and the hourly operational system-state profile curve of the distribution line. Customer Margin is the Energy Not Supplied (ENS) to a customer at a given hour. Table 3.1 summarizes the different cases of the Customer Margin.

Using the Customer Margin, the system reliability index LOEE, and the customer reliability index AENS are calculated using the following equations.

$$AENS_j = \frac{\sum_{i=1}^N ENS_{(customer_j)_i}}{N} \quad (3.1)$$

$$LOEE = \frac{\sum_{i=1}^N ENS_{(system)_i}}{N} \quad (3.2)$$

Where N denotes the number of iterations/years and $ENS_{customer}$ denotes total Energy Not Supplied (MWh) to customer j in a given year. The sum of ENS of all the customers in the distribution system gives the ENS_{system} . The value of ENS per iteration per customer is the sum of hourly Customer Margin (CM).

3.6.2 Phase II – After Installing CHP Units

Phase II includes all the simulations performed in Phase I plus the simulation of the CHP units that are considered to operate at various customer sites.

Table 3.1: Customer Margin - Phase I

Condition 1	Condition 2	Value of the Customer Margin
Total power generated by utility operated units is greater than or equal to total system load	State of the distribution line is UP	Zero
	State of the distribution line is DOWN	Portion of customer load not supplied
Total power generated by utility operated units is lesser than total system load	State of the distribution line is UP	Portion of customer load not supplied
	State of the distribution line is DOWN	Portion of customer load not supplied

Thus, in Phase II, the New Customer Margin is determined by superimposing the hourly load curve, the hourly system power curve of the utility owned generation units, the hourly operational system-state profile curve of the distribution line and the hourly CHP units power curve. The New Customer Margin is then used to calculate the New AENS and the New LOEE using equations (3.1) and (3.2). Table 3.1 summarizes the different cases of the New Customer Margin.

By comparing the AENS and the LOEE, obtained in phase I, with the New AENS and the New LOEE, obtained in phase II, the contribution of CHP units to system reliability and the customer reliability can be evaluated.

Table 3.2: New Customer Margin – Phase II

Condition 1	Condition 2	Condition 3	Value of the Customer Margin
Total power generated by utility operated units is greater than or equal to total system load	State of the distribution line is UP	CHP power is zero, greater than, lesser than or equal to the customer load	Zero
	State of the distribution line is DOWN	CHP power is greater than or equal to the customer load	Zero
		CHP power is zero or lesser than the customer load	Portion of customer load not supplied
Total power generated by utility operated units is lesser than total system load	State of the distribution line is UP	Power generated by utility units plus CHP power is greater than or equal to the customer load	Zero
		Power generated utility units plus CHP power is lesser than the customer load	Portion of customer load not supplied
	State of the distribution line is DOWN	CHP power is greater than or equal to the customer load	Zero
		CHP power is zero or lesser than or equal to the customer load	Portion of customer load not supplied

CHAPTER 4

DISTRIBUTION SYSTEM MODELING – BASIC TECHNIQUES

This chapter is concerned with the basis evaluation techniques of simple radial distribution systems. The technique is based on approximate equations for evaluating the rate and duration of outages that was first published in 1964-65 [15]. The techniques required to analyze a distribution system depend on the type of system being considered and the depth of analysis needed.

4.1 Evaluation Techniques

A radial distribution system consists of a set of series components, including lines, cables, disconnects (or isolators), busbars, etc. Henceforth, for simplicity, the term “distribution line” would be used to collectively refer all the components that connect a load point to a supply point. A customer connected to any load point of such a system requires all components between himself and the supply point to be operating, in other words, the distribution line should be in UP state. The concept of series systems can be applied to these systems which results in the following equations for the three basic reliability parameters, viz., average failure rate, λ_s , average outage time, r_s , and average annual outage time, U_s .

$$\lambda_s = \sum_i \lambda_i \quad (4.1)$$

$$U_s = \sum_i \lambda_i r_i \quad (4.2)$$

$$r_s = \frac{U_s}{\lambda_s} = \frac{\sum_i \lambda_i r_i}{\sum_i \lambda_i} \quad (4.3)$$

In section 4.2, the method to obtain the operational history of the distribution line using the basic reliability indices, is explained.

Consider the radial system shown in Fig. 4.1. It is a simple system and any fault, single phase or otherwise will trip all the three phases.

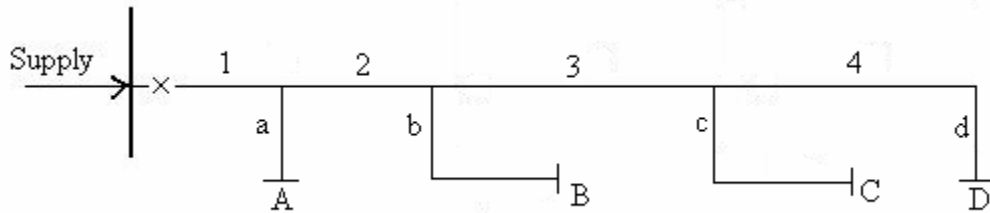

Figure 4.1: Simple 3-Load Point Radial System

The assumed failure rates and repair times of each component are shown in Table 4.1. It shall be observed that the failure rate of lines and cables is proportional to their length.

Using, the above equations the load point reliability indices are calculated and are listed in Table 4.2. In this example, the reliability of each load point is identical. The operating policy assumed for this system is not very realistic and additional features such as isolation, additional protection and transferable loads can be included. These features are discussed in the following sections.

Table 4.1: Component Data for the System shown in Fig. 4.1

Component	Length (km)	Failure Rate, λ (failures/year)	Repair Time, r (hours)
1	2	0.2	4
2	1	0.1	4
3	3	0.3	4
4	2	0.2	4
a	1	0.2	2
b	3	0.6	2
c	2	0.4	2
d	1	0.2	2

Table 4.2: Load-Point Reliability Indices for the System of Fig. 4.1

Load Point	Failure Rate, λ_L (failures/year)	Repair Time, r_L (hours)	U_L (hours/yr)
A	2.2	2.73	6
B	2.2	2.73	6
C	2.2	2.73	6
D	2.2	2.73	6

4.1.1. Effect of lateral distributor protection

Additional protection is frequently used in practical distribution systems. One possibility in the case shown in Fig. 4.2 is to install fuse-gear at the tee-point in each lateral distributor. In this case a short circuit on a lateral distributor causes its appropriate fuse to blow; this causes disconnection of its load point until the failure is repaired but does not

affect or cause the disconnection of any other load point. The load point reliability indices that take into the consideration the effect of later distribution protection are shown in Table 4.3.

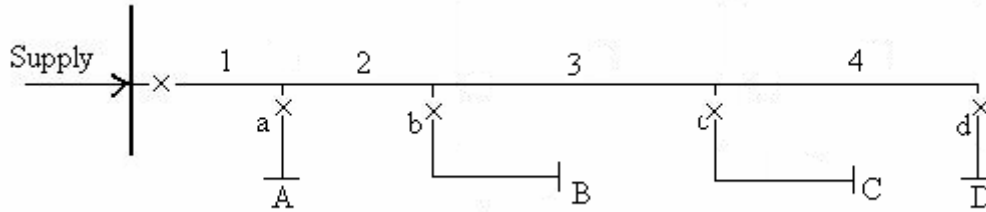

Figure 4.2: System of Fig. 4.1 with Lateral Protection

It shall be observed that the reliability indices are improved for all load points although the amount of improvement is different for each one.

Table 4.3: Reliability Indices with Lateral Protection

Load Point	Failure Rate, λ_L (failures/year)	Repair Time, r_L (hours)	U_L (hours/yr)
A	1.0	3.6	3.6
B	1.4	3.14	4.4
C	1.2	3.33	4.0
D	1.0	3.6	3.6

4.1.2. Effect of disconnects

A second or alternative reinforcement or improvement scheme is the provision of disconnects or isolators at judicious point along the main feeder. These are generally not fault-breaking switched and therefore any short circuit on a feeder still causes the main breaker to operate. After the fault has been located, however, the relevant disconnect can be

opened and the breakers reclosed. This procedure allows restoration of all load points between supply point and the point of isolation before the repair process has been completed. Let points of isolation be installed in the previous system as shown in Fig. 4.3 and let the total isolation and switching be 0.5 hour.

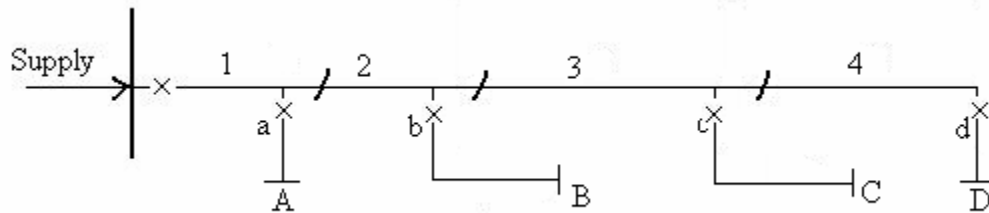

Figure 4.3: Network of Fig. 4.1 with Disconnects and Lateral Protection

The reliability indices for the four load points are now modified to those shown in Table 4.4.

Table 4.4: Reliability Indices with Disconnects and Lateral Protection

Load Point	λ_L (failures/year)	r_L (hours)	U_L (hours/yr)
A	1.0	1.5	1.5
B	1.4	1.89	2.65
C	1.2	2.75	3.3
D	1.0	3.6	3.6

In the examples of section 4.1.1 and 4.1.2, it is assumed that the lateral protections and disconnects are 100% reliable.

4.2 Evaluation of the distribution system for busbar 2 of IEEE-RBTS

For the distribution system considered in this thesis, the evaluation technique includes the reliability of the following components: 33kV supply feeders, 11kV feeders, transformers, breakers, busbars, and lines. The lateral protection and disconnects are assumed to be 100% reliable. The system is considered to be a simple radial network. The failure rates and repair times for various components of the distribution system that connects each load point to the supply point is given in Table B.2 of Appendix B. Using the basic reliability indices of various components and the method explained in section 4.1.2 the basic reliability indices for each distribution line is calculated. Remember that a distribution line is used to refer all the components that connect the load point to the supply point. The reliability parameters, Failure Rate (inverse of MTTF) and Repair Time (MTTR), for the 22 load points (distribution lines) are listed in Table 4.5. The calculations used to evaluate the reliability parameters are shown in Table D.1 of Appendix D.

4.3 Distribution system modeling and simulation

The modeling method is based on the treatment of a distribution line as a two state system: UP state and DOWN state. The UP state indicates that the distribution line is operational and thus the load point is connected to the supply point. In other words, UP state indicates that all the components connecting the load point to a supply point is operational. The DOWN state implies that one of the components in the distribution line has failed and thus the load point is not connected to the supply point.

Table 4.5: Basic Reliability Indices for Load Points of Busbar 2 of IEEE-RBTS

Load Point	Total Failure Rate (f/yr)	Total Repair Time (hr)
1	0.2801	29.71
2	0.2931	28.62
3	0.2931	29.28
4	0.2801	30.41
5	0.2931	29.95
6	0.2898	30.23
7	0.2931	30.48
8	0.1746	27.83
9	0.1746	27.83
10	0.2833	29.39
11	0.2931	29.28
12	0.2963	29.02
13	0.2931	29.82
14	0.2963	29.54
15	0.2833	31.36
16	0.2931	28.62
17	0.2833	29.43
18	0.2833	30.12
19	0.2963	29.02
20	0.2963	29.68
21	0.2931	30.48
22	0.2963	30.20

The transition from one stage to another is determined using the parameters Mean Time to Failure, (MTTF – from UP to DOWN) and Mean Time to Repair (MTTR – from DOWN to UP).

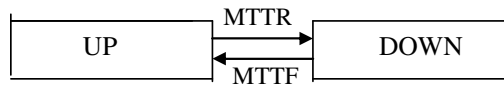

Figure 4.4: Two-Stage Distribution Line Model

The MTTF is the product of the inverse of failure rate and the number of hours being considered per iteration, in this case, 8,736 hours. The MTTR is the repair rate. At the start of

the simulation, the distribution line is assumed to be in UP state. The simulation of the distribution system is based on the State Duration Sampling approach. A sample distribution line operational state history was shown in Fig. 3.6.

CHAPTER 5

CASE STUDIES & RESULTS – PART I

Various case studies were conducted as part of this thesis. This chapter explains the purpose of each case study, the method and data used in each case study. The results obtained in each case study are also presented. The following section elaborates on aspects that are common to all the case studies.

5.1 Common Aspects

The IEEE-RTS and the IEEE-RBTS have been extensively used in reliability analysis of power systems. Together they provide a standard test platform for comparison between various reliability evaluation techniques. Unavailability of real-time data is also a motivation to use IEEE-RTS and IEEE-RBTS data. In all the case studies, the generation system is modeled based on the IEEE-RTS data and configuration.

The IEEE – RTS and the IEEE – RBTS were outlined in section 2.4. Appendix A and Appendix B summarizes all the relevant information from IEEE – RTS and IEEE – RBTS that are used in this thesis.

The second phase in the case studies involves installation of CHP units at various customer sites. All such customers are located in the distribution system of busbar 2. The basic reliability parameters for various sizes of CHP units are given in Table C.1 of Appendix C [16]. The load profiles for the customers connected to various load points are given in Figure B.2 through Figure B.23 of Appendix B.

For the case studies discussed in this chapter, the availability of the CHP units is determined using the reliability parameters of the units.

5.2 Case Study 1

In order for the results obtained in this thesis to be meaningful, it is first necessary to validate the model, especially, the modeling of the distribution system for reliability evaluation. The primary purpose of case study 1 is to validate the modeling of the distribution system. In this case study, the reliability of power supply to a customer when it is connected to load point 16 is compared to that of a customer connected to load point 22. The two customers have the same load characteristics. The hourly load curve of the customer(s) for one year is shown in Figure 5.1.

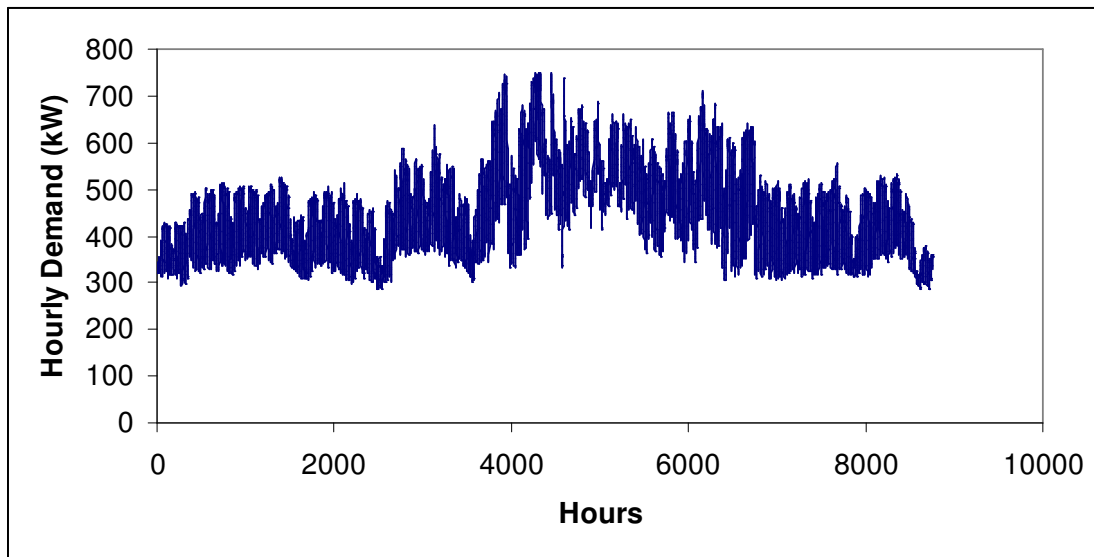

Figure 5.1: Load Curve for the Customer(s) that is Studied in Case Study 1

According to the IEEE-RBTS, load point 16 and load point 22 have similar peak and average load. This enables comparison and interpretation of the reliability values, the results of this case study, straightforward.

The load point 16 is located closer to the supply point, the 33kV busbar 2, than the load point 22. Thus due to the difference in distance from the supply point and the number of components in the distribution line, the reliability of power supply to load point 16 is

expected to be higher than that to load point 22. This conjecture is verified in case study 1. Case Study 1 consists just one phase and is concerned with the evaluation of AENS for load points 16 and 22. It involves generation modeling, load modeling, and distribution system modeling (no CHP generation modeling).

5.2.1 Results of Case Study 1

The reliability index, AENS, for the customers at load point 16 and 22 is evaluated and compared. Fig 5.2 compares the Monte Carlo convergence of AENS for the customer at load point 16 versus the customer at load point 22.

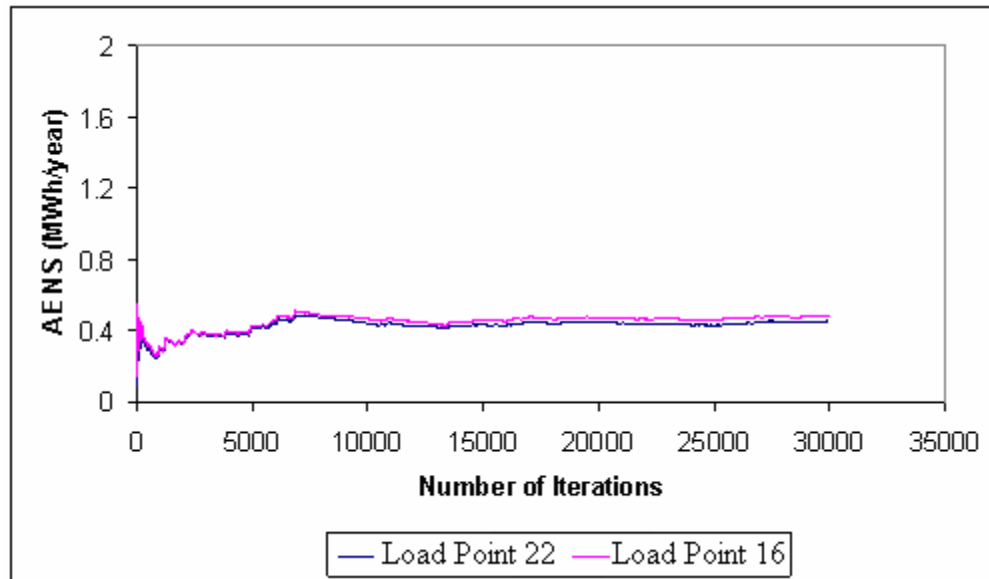

Figure 5.2: Monte Carlo Convergence of AENS for the Customer at Load Point 16 and Load Point 22

The AENS for the customer at load point 16 is 0.4547MWh/year which represents a reliability of **99.9885%**. The AENS for the customer at load point 22 is 0.4792MWh/year which represents a reliability of **99.9879%**.

Similar comparison can be made between the load points 16 and 6. Load points 16 and 6 also have similar average and peak loads, but load point 6 is farther from the supply

point than load point 16. The AENS for the customer at load point 6 is found to be 0.4684MWh/year which represents a reliability of 99.9882%. Fig.5.3 compares the Monte Carlo convergence of AENS for the customer at load point 16 versus the customer at load point 6.

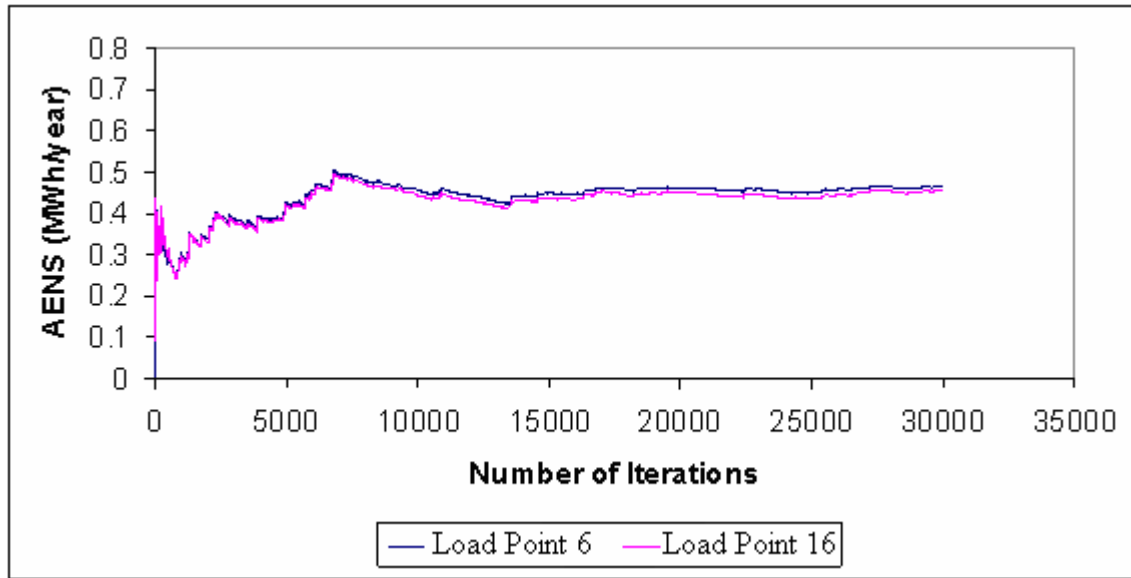

Figure 5.3: Monte Carlo Convergence of AENS for the Customer at Load Point 16 and Load Point 6

The reliability of power supply to load point 16 is higher than that to load point 22 or load point 6. The lesser reliability of power supply to load point 22 or 6 is attributed to their longer distance from the supply point and (un)reliabilities of additional components in the distribution line that connect load point 22 and 6 to the supply point. This case study thus validates the distribution system modeling which is an important part of this thesis.

5.3 Case Study 2

In a study conducted by Tejal Kanitkar [14], one of the main conclusions was that the reliability is maximized when three CHP units are operated by the customer and such that the

combined capacity of the three units is equal to the peak load of the customer. The study includes generation system modeling, CHP generation modeling but excludes the reliability evaluation of the distribution system. The primary purpose of this case study is to verify the conclusion made in the work [14] while including the reliability of the distribution system. Accordingly, the reliability index, AENS, was evaluated for the customer at the load point 22 before and after the installation of the CHP units at the customer site. This case study consists of three phases. In phase I, the AENS is evaluated with no CHP units operating at the customer site. In phase II, the AENS is evaluated while two CHP units are considered to be operating at the customer site. The sum of the capacities of the two units is equal to peak load (750 kW) of the customer. Thus, the capacity of the CHP units is 375 kW each. In phase III, the AENS is evaluated while three CHP units are considered to be operating at the customer site. Since the sum of the capacities of the three units should be equal to the peak load of the customer, the capacity of the CHP units is 250 kW each. This case study involves generation modeling, load modeling, distribution system modeling and CHP generation modeling.

5.3.1 Results of Case Study 2

For Phase I, that is for the case with no CHP units operating at the customer site, Figure 5.4 shows the Monte Carlo convergence of AENS for the customer. Figure 5.5 compares the Monte Carlo convergence of AENS for the customer obtained with the CHP units. The results of the case study are summarized in Table 5.1. It shall be observed that the percentage improvement in reliability is greater for the case with three 250kW CHP units when compared to that with two 375 kW CHP units.

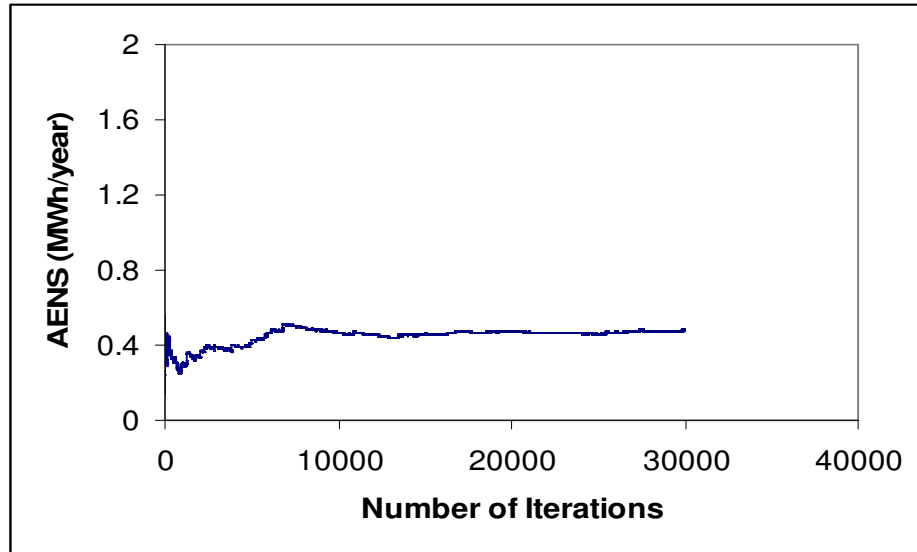

Figure 5.4: Monte Carlo Convergence of AENS for Customer 22 with No CHP Units at Customer Site

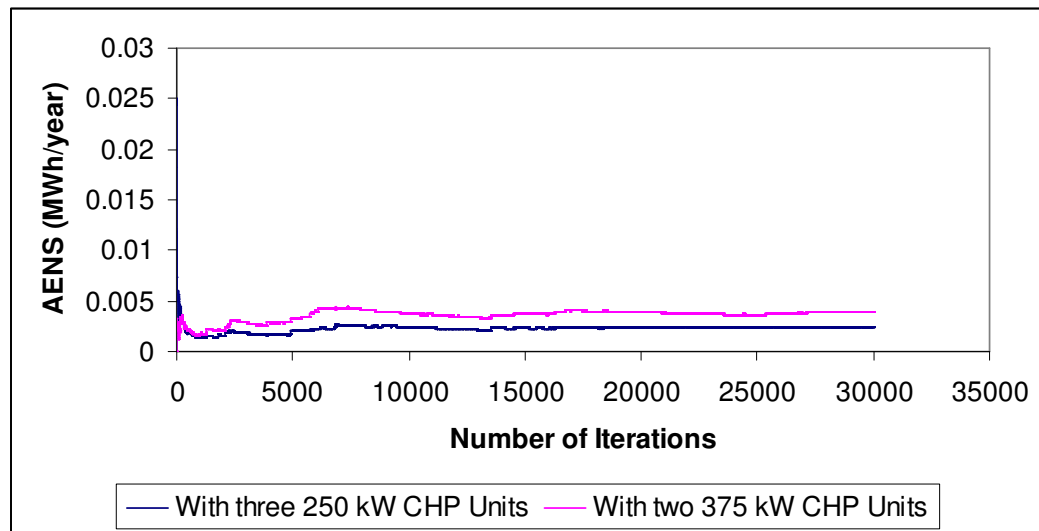

Figure 5.5: Comparison of Monte Carlo Convergence of AENS for Customer 22 with Two CHP Units and Three CHP Units

Table 5.1: Results of Case Study - 2

Phase	AENS (MWh/year)	Percentage Reliability (%)	Percentage Improvement in Reliability (%)
I – With No CHP Units	0.47917	99.98792	-
II – With two 375kW CHP Units	0.00389	99.99990	99.18818
III –With three 250kW CHP Units	0.00243	99.99994	99.49287

5.4 Case Study 3

From the previous two case studies it is also verified that the operation of CHP units at a customer site, indeed, improves the reliability of power supply to the customer. Further observation reveals that when a customer obtains part or its entire load from onsite CHP units, that portion of the load becomes invisible to the power grid. This is equivalent to adding additional capacity to the power grid thus improving the overall system reliability. This and the next case study deals with estimating the amount of improvement in overall system reliability as increasing number of customers utilize onsite CHP units for electric power supply.

This case study consists of two phases. In phase I, the customer reliability index, the AENS, and the system reliability index, the LOEE are evaluated with no CHP units operating in the system. In phase II, the AENS and LOEE are evaluated with CHP units operating at certain customer sites. In case study 2, it was verified that the optimum number of CHP units operating at a customer site for maximum reliability, is three. Thus, in phase II of case study 3, three CHP units are considered to be operating at each of the chosen customer sites. The

sizes of the CHP units operated by each customer in various experiments are listed in Table 5.2. Table 5.3 summarizes the details of analysis conducted in phase II of case study 3.

Table 5.2: Details of Case Study 3 – Phase II- Experiment 1 to 5

Load Point	Size of One Unit (MW)	Generation Capacity of CHP System (MW)
1	0.300	0.900
2	0.300	0.900
3	0.300	0.900
4	0.325	0.975
5	0.325	0.975
6	0.250	0.750
7	0.250	0.750
8	0.550	1.650
9	0.625	1.875
10	0.300	0.900
11	0.300	0.900
12	0.250	0.750
13	0.325	0.975
14	0.325	0.975
15	0.250	0.750
16	0.250	0.750
17	0.250	0.750
18	0.250	0.750
19	0.250	0.750
20	0.325	0.975
21	0.325	0.975
22	0.250	0.750

5.4.1 Results of Case Study 3

In the previous two case studies only the customer reliability index, AENS, was examined. In this case study, the main focus is on the system reliability index, LOEE.

Phase I – Case Study 3

In phase I, the LOEE and AENS are evaluated with no CHP units operating in the

distribution system. The Monte Carlo convergence of the system reliability index, LOEE, is shown in Figure 5.6. The LOEE is found to be 12.8807 MWh/year which represents a system reliability of **99.9880%**. Table 5.4 lists the AENS and the percentage reliability for the 22 customers.

Table 5.3: Details of Case Study 3 – Phase II- Experiment 1 to 5

	CHP Generation as a Percentage of Total Distribution System Load	Customers that Operate CHP units	Total CHP Generation Capacity (MW)
Experiment 1	8%	Load Point 8	1.63
Experiment 2	15.5%	Load Points 8,12 and 16	3.11
Experiment 3	24.9%	Load Points 8,12,16 and 9	4.98
Experiment 4	48.4%	Load Points 8,12,16,9,10,11, 17,19,6 and 22	9.67
Experiment 5	73.3%	Load Points 8,12,16,9,10,11, 17,19,6,22,1,2,3, 7,18 and 4	14.67
Experiment 6	95.4%	Load Points 8,12,16,9,10,11, 17,19,6,22,1,2,3, 7,18,4,15,5,13,14 and 20	19.08
Experiment 7	100%	Load Points 8,12,16,9,10,11, 17,19,6,22,1,2,3, 7,18,4,15,5,13,14,20 and 21	20.00

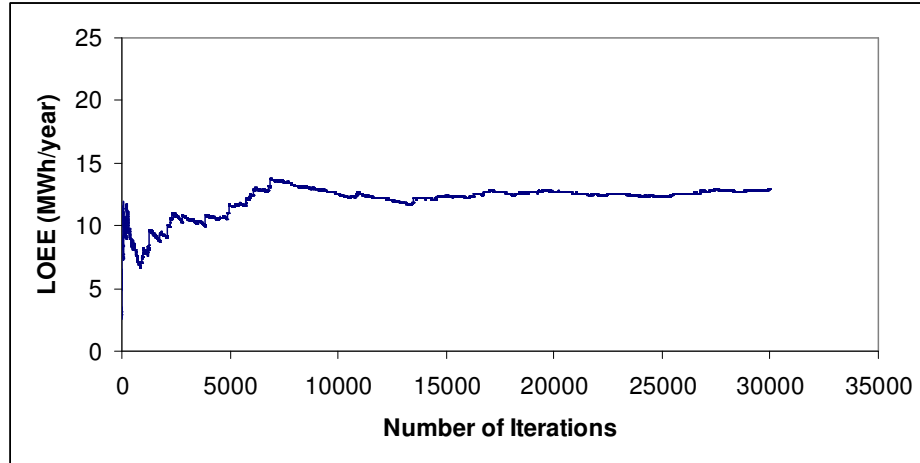

Figure 5.6: Monte Carlo Convergence of LOEE for Case Study 3 - Phase I

Table 5.4: AENS and the Percentage Reliability for the 22 Customers in Case Study 3 Phase 1

Customer at Load Point	Average Load (MW)	Peak Load (MW)	AENS (MWh/year)	Percentage Reliability (%)
1	0.535	0.8668	0.5250	99.99307
2	0.535	0.8668	0.5796	99.99235
3	0.535	0.8668	0.5309	99.99299
4	0.566	0.9167	0.5600	99.99301
5	0.566	0.9167	0.5783	99.99278
6	0.454	0.7500	0.4684	99.99285
7	0.454	0.7500	0.4414	99.99326
8	1.000	1.6279	1.0081	99.99291
9	1.150	1.8721	1.1625	99.99289
10	0.535	0.8668	0.5536	99.99269
11	0.535	0.8668	0.5411	99.99285
12	0.450	0.7291	0.5466	99.99142
13	0.566	0.9167	0.6815	99.99149
14	0.566	0.9167	0.6355	99.99206
15	0.454	0.7500	0.4802	99.99267
16	0.454	0.7500	0.4547	99.99306
17	0.450	0.7291	0.5464	99.99142
18	0.450	0.7291	0.3903	99.99387
19	0.450	0.7291	0.5511	99.99135
20	0.566	0.9167	0.5638	99.99296
21	0.566	0.9167	0.5928	99.99260
22	0.454	0.7500	0.4792	99.99269

Phase II – Case Study 3

In this phase CHP units are considered to be operating at customer sites as listed in Table 5.3. Three CHP units of equal capacity are considered to operate at each customer site such that the sum of the capacity of three units is equal to the peak load of the customer. When the power generated by the CHP units is less than the customer load or when all three units fail the customer is supplied with power by the utility operated grid.

The new LOEE index obtained in phase II are summarized in Table 5.5. Figure 5.7 shows the percentage reliability for each experiment as a function of percentage of total distribution system load that is CHP generation.

Table 5.5: New LOEE Index, Percentage Reliability for Phase II Case Study 3

Experiment 1	8%	10.7427	99.99000	16.59847
Experiment 2	15.5%	9.7784	99.99089	24.08470
Experiment 3	24.9%	8.6528	99.99194	32.82319
Experiment 4	48.4%	5.7831	99.99461	55.10232
Experiment 5	73.3%	3.4836	99.99668	72.95489
Experiment 6	95.4%	0.8073	99.99925	93.73248
Experiment 7	100%	0.2442	99.99977	98.10452

From Table 5.5 and Figure 5.7 it is observed that the overall reliability of a system, the LOEE, increases with increase in installed CHP capacity. However, the rate of improvement in reliability is found to be decreasing with increase in CHP capacity. For example, when the CHP capacity is increased from 8% (Experiment 1) to 15.5% (Experiment 2), an increase of 7.5%, the percentage improvement in reliability increases from 16.59847% to 24.08470%, an increase of 7.49%. However, the increase in CHP capacity between experiment 2 and 3 is 9.4%, the increase in percentage improvement in reliability is only 8.74%.

This aspect, which follows the Law of Diminishing Marginal Returns, should be carefully considered during the planning stage of CHP capacity addition to a distribution system. It is necessary to determine the economically optimum CHP capacity that shall added to a distribution system.

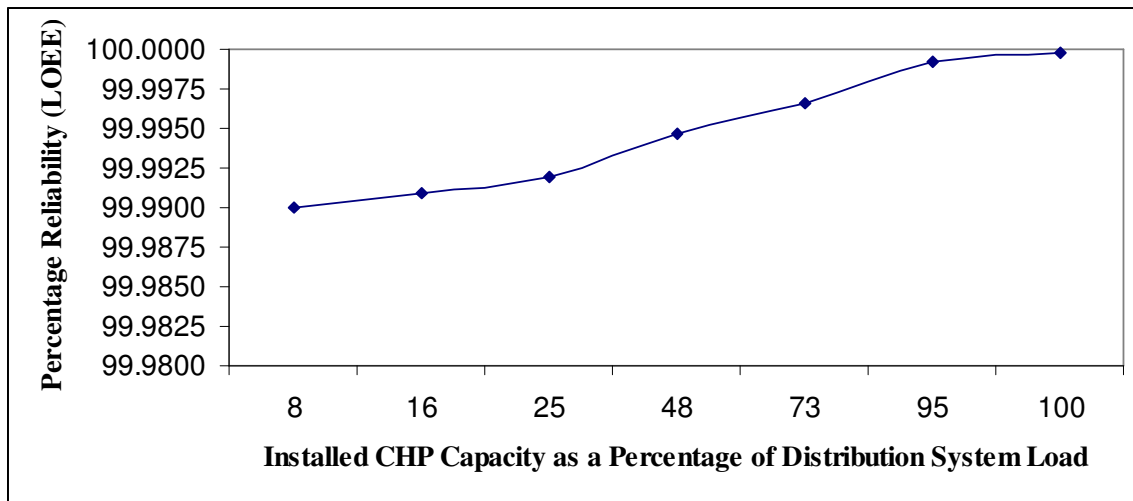

Figure 5.7: Percentage Reliability, LOEE - Case Study 3

It shall be observed that the experiments were designed also to understand the effect of increasing CHP capacity in a distribution system on individual customer reliability. For example, the customer at load point 8 is included in all the experiments. The LOEE index for customer 8 for each experiment is shown in Table 5.6 and the same is plotted in Figure 5.8.

It is observed that the reliability index for customer 8, AENS, increases with increase in installed CHP capacity. However, the rate of increase in percentage improvement in reliability of power supply decreases with installed CHP capacity.

The AENS values calculated for all the customers in each experiment is shown in Table E.1 to Table E.7 of Appendix E. From the Tables it is observed that the amount of percentage improvement in reliability of power supply to each customer decreases with increase in installed CHP capacity in the system.

Table 5.6: New AENS Index, Percentage Reliability for Customer 8 – Case Study 3

	CHP Generation as a Percentage of Total Distribution System Load	AENS (MWh/year)	Percentage Reliability (%)	Percentage Improvement in Reliability (%)
Phase I	0%	1.008070	99.992912	-
Experiment 1	8%	0.010745	99.999924	98.9341
Experiment 2	15.5%	0.010611	99.999925	98.9474
Experiment 3	24.9%	0.010467	99.999926	98.9617
Experiment 4	48.4%	0.010339	99.999927	98.9744
Experiment 5	73.3%	0.010211	99.999928	98.9871
Experiment 6	95.4%	0.010097	99.999929	98.9984
Experiment 7	100%	0.010054	99.999929	99.0026

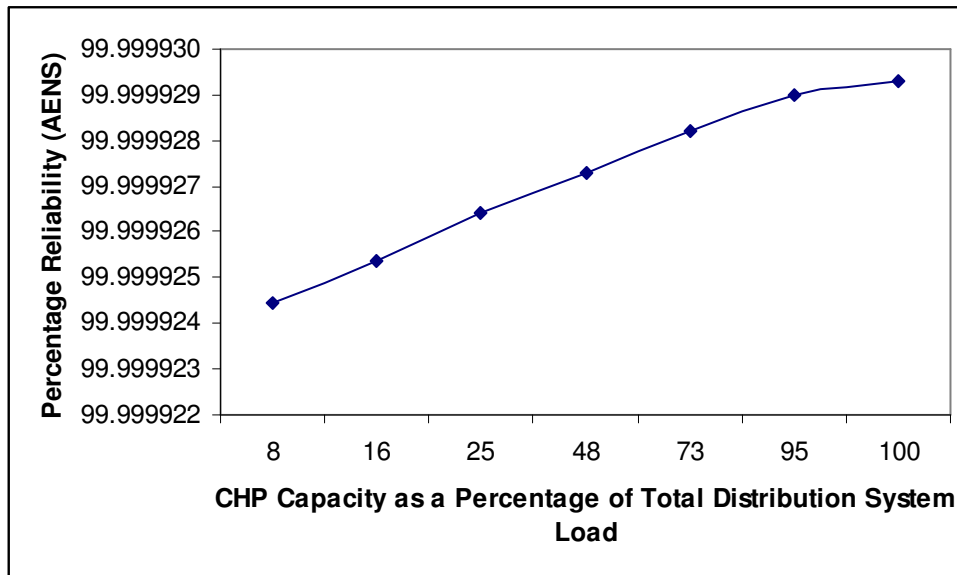

Figure 5.8: Percentage Reliability, AENS, for Customer 8 – Case Study 3

5.5 Case Study 4

In this case study it is shown that the system reliability for the IEEE-RBTS system is of the order of 99.95%. This is low when compared to real world conditions where the reliability is of the order of 99.99%.

In case studies 1 through 3 it shall be observed that the values of reliability indices are of the order of 99.99%. This order of values corroborates with the reliabilities of practical systems. The higher reliability in practical power systems is mainly due to the fact that the shutdown of most utility operated generation units and the maintenance shutdown of customer operated CHP units are planned.

In Case study 4 the actual reliability indices are evaluated for the IEEE-RBTS is evaluated.

5.5.1 Results of Case Study 4

In phase I, the LOEE and AENS are evaluated with no CHP units operating in the distribution system. The Monte Carlo convergence of the system reliability index, LOEE, is shown in Figure 5.8.

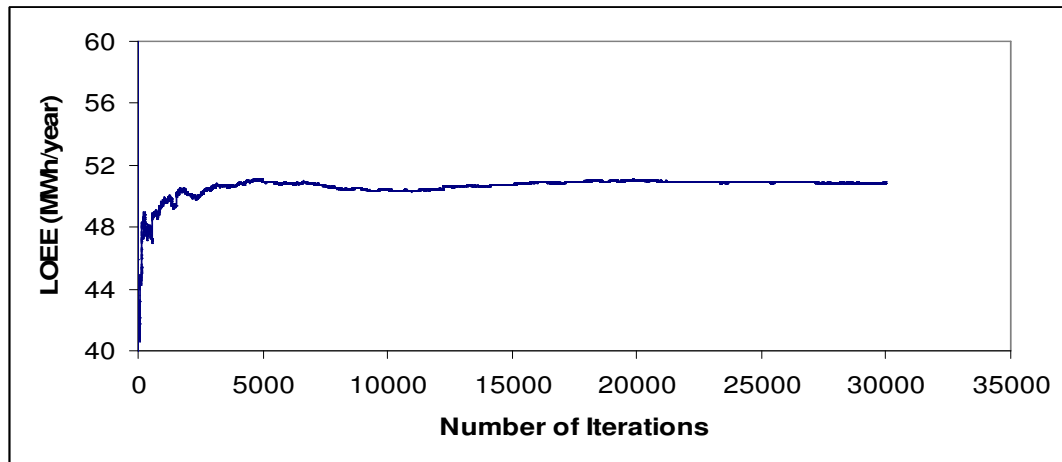

Figure 5.8: Monte Carlo Convergence of LOEE for Case Study 4 Phase I

The LOEE is found to be 50.86 MWh/year which represents a system reliability of **99.95263%**. Table 5.7 lists the AENS and the percentage reliability for the 22 customers.

Table 5.7: AENS and the Percentage Reliability for the 22 Customers in Phase I - Case Study
4

Customer at Load Point	Average Load (MW)	Peak Load (MW)	AENS (MWh/year)	Percentage Reliability (%)
1	0.535	0.8668	1.97346	99.957776
2	0.535	0.8668	2.06976	99.955715
3	0.535	0.8668	2.16683	99.953638
4	0.566	0.9167	2.34138	99.952648
5	0.566	0.9167	2.43805	99.950692
6	0.454	0.7500	1.93537	99.951203
7	0.454	0.7500	2.05265	99.948246
8	1.000	1.6279	3.74209	99.957165
9	1.150	1.8721	4.79239	99.952297
10	0.535	0.8668	2.08473	99.955395
11	0.535	0.8668	2.20231	99.952879
12	0.450	0.7291	1.89157	99.951883
13	0.566	0.9167	2.47258	99.949994
14	0.566	0.9167	2.49803	99.949479
15	0.454	0.7500	2.07551	99.947669
16	0.454	0.7500	1.75267	99.955809
17	0.450	0.7291	1.70254	99.956692
18	0.450	0.7291	1.76342	99.955143
19	0.450	0.7291	1.87051	99.952419
20	0.566	0.9167	2.46231	99.950202
21	0.566	0.9167	2.53036	99.948826
22	0.454	0.7500	2.04461	99.948448

The phase II of this case study is similar to that of case study 3 in that the experiments conducted are the same as explained in Table 5.2. Table 5.8 shows the system reliability index, the new LOEE, and the percentage improvement in LOEE. Table 5.9 shows the customer reliability index, the new AENS.

Table 5.8: New LOEE Index, Percentage Reliability for Phase II Case Study 4

	CHP Generation as a Percentage of Total Distribution System Load	LOEE (MWh/year)	Percentage Reliability (%)	Percentage Improvement in Reliability (%)
Experiment 1	5%	48.53	99.95480	4.58
Experiment 2	15%	43.49	99.95950	14.49
Experiment 3	25%	38.49	99.96415	24.32
Experiment 4	50%	25.72	99.97605	49.43

Table 5.9: New AENS Index, Percentage Reliability for Phase II Case Study 4

	CHP Generation as a Percentage of Total Distribution System Load	Customers that Operate CHP units	AENS (MWh/year)	Percentage Reliability (%)
Experiment 1	5%	Load Point 4	0.00062	99.99999
Experiment 2	15%	Load Point 8	0.01270	99.99985
		Load Point 12	0.02029	99.99948
		Load Point 16	0.00700	99.99982
Experiment 3	25%	Load Point 2	0.00407	99.99991
		Load Point 8	0.01282	99.99985
		Load Point 9	0.00954	99.99991
		Load Point 18	0.01821	99.99954
Experiment 4	50%	Load Point 3	0.01743	99.99963
		Load Point 5	0.00867	99.99982
		Load Point 8	0.01080	99.99988
		Load Point 9	0.00808	99.99992
		Load Point 10	0.00494	99.99989
		Load Point 12	0.01896	99.99952
		Load Point 14	0.01347	99.99973
		Load Point 15	0.01604	99.99960
		Load Point 16	0.00743	99.99981
Load Point 18	0.02027	99.99948		

In Table 5.10 the AENS values obtained in Phase I and Phase II are compared.

Table 5.10: Percentage Improvement in Reliability for the Customers Studied in Phase II - Case Study 4

	Customers that Operate CHP units	AENS - Phase I (MWh/year)	AENS - Phase II (MWh/year)	Percentage Improvement in Reliability (%)
Experiment 1	Load Point 4	2.34138	0.00062	99.9735
Experiment 2	Load Point 8	3.74209	0.01270	99.6606
	Load Point 12	1.89157	0.02029	98.9273
	Load Point 16	1.75267	0.00700	99.6006
Experiment 3	Load Point 2	2.06976	0.00407	99.8034
	Load Point 8	3.74209	0.01282	99.6574
	Load Point 9	4.79239	0.00954	99.8009
	Load Point 18	1.76342	0.01821	98.9673
Experiment 4	Load Point 3	2.16683	0.01743	99.1956
	Load Point 5	2.43805	0.00867	99.6444
	Load Point 8	3.74209	0.01080	99.7114
	Load Point 9	4.79239	0.00808	99.8314
	Load Point 10	2.08479	0.00494	99.7630
	Load Point 12	1.89157	0.01896	98.9977
	Load Point 14	2.49803	0.01347	99.4608
	Load Point 15	2.07551	0.01604	99.2272
	Load Point 16	1.75267	0.00743	99.5761
	Load Point 18	1.76342	0.02027	98.8505

For this case study, the Table F.1 to Table F.5 of Appendix F compares the AENS and new AENS values for all the customers in each experiment. The results obtained in this case study augments the results obtained in case study 3. It is found that CHP units contribute significantly to the overall system reliability and the reliability of power supply to individual customers. Once again, the amount of improvement is found to be decreasing with increase in CHP capacity in the distribution system.

5.6 Case Study 5

CHP units, or in general, DG units, that are operated by customers improve the reliability of power supply to the customer and the overall system reliability. However, given a set of economic constraints, such as, funding is available only to install a limited capacity

and number of CHP units in a distribution system, it is crucial to determine where the CHP units should be located.

In the first experiment of this case study, the AENS index is compared for two customers before and after installation of CHP units at their sites. The two customers are the one at Load Point 22 (the farthest point from the bus) and one at Load Point 16, which is the closest point to Bus 2. In the second experiment, the simulation is repeated with decreased MTTF and increased MTTR values for the 11kV breaker and the 11/0.415kV transformer which connects the Load Point 16 to the feeder section. The reliability parameters for the distribution line that connects customer 22 and customer 16 to the bus 2 are summarized in Table 5.11.

Table 5.11: Reliability Parameters of the Distribution Line that Connects Customer 16 and Customer 22 to the busbar 2

	Customer 16		Customer 22	
	Failure Rate, λ_L (failures/year)	Repair Time, r_L (hours)	Failure Rate, λ_L (failures/year)	Repair Time, r_L (hours)
Experiment 1	0.293	28.62	0.296	30.20
Experiment 2	0.377	81.41	0.296	30.20

Each experiment consists of two phases: Phase I – without CHP units and Phase II- with CHP units. The results of Experiment 1 and Experiment 2 are shown in Table 5.12 and 5.13 respectively.

Table 5.12: Results of Experiment 1 - Case Study 5

AENS (MWh/year) for Customer 16			AENS (MWh/year) for Customer 22		
Phase I - Without CHP Units	Phase II - With three 250 kW CHP Units	Percentage Improvement in Reliability (%)	Phase I - Without CHP Units	Phase II - With three 250 kW CHP Units	Percentage Improvement in Reliability (%)
0.45470	0.00231	99.49192	0.47920	0.00242	99.49382

Table 5.13: Results of Experiment 2 - Case Study 5

AENS (MWh/year) for Customer 16			AENS (MWh/year) for Customer 22		
Phase I - Without CHP Units	Phase II - With three 250 kW CHP Units	Percentage Improvement in Reliability (%)	Phase I - Without CHP Units	Phase II - With three 250 kW CHP Units	Percentage Improvement in Reliability (%)
0.50751	0.00273	99.4621	0.47936	0.00263	99.4514

From Table 5.12 it is observed that the percentage improvement in reliability for the Load Point 22 customer is greater than that for the Load Point 16 customer. Thus the CHP's ability to improve a customer's reliability is a function of the distance of the customer from the supply point. On the other hand the results of experiment 2, as shown in Table 5.13, indicates that the percentage improvement in reliability for the Load Point 16 customer is greater than that for the Load Point 22 customer. This shows that the CHP's ability to improve a customer's reliability is a function of the reliability of the components that connect the customer to the busbar. Thus it is inferred that the CHP's ability to improve a customer's reliability is a function of the distance of the customer from the supply point and the reliability of the components in the distribution line.

CHAPTER 6

CASE STUDY - 7

In the experiments presented in the previous chapter the sizes of the CHP units are based on the peak electric load of the customers. It was assumed that the combined size of the CHP units is equal to the peak load of the load point where the CHP units are operated. Also, the operation of the CHP units was determined by the reliability parameters of the CHP units only. From the perspective of reliability evaluation those experiments represent an ideal case approach for reliability evaluation of DG units. However a more specific approach shall be applied to customer operated CHP units.

In practical scenarios the generation profile of a customer operated CHP unit usually follows the thermal and/or electric load of the customer. The most common scenario is that the CHP unit is sized to supply the base thermal load of the customer. Since a CHP unit caters to both thermal and electric requirements of a customer, the sizing of a CHP unit, unlike other DG technologies, takes the form of an optimization problem. The objective of such a problem is to determine the optimal CHP unit size given the constraints such as customer thermal load profile, customer electric load profile, cost of the fossil fuel and cost of utility supplied electricity and the technology. The most typical case is that the final thermal energy output of the CHP unit is equal to the base thermal load of the customer. Also, customers usually install more than one unit to meet peak load requirements.

For example, consider the customer with the thermal load and the electric load as shown in Figure 6.1 and Figure 6.2 respectively.

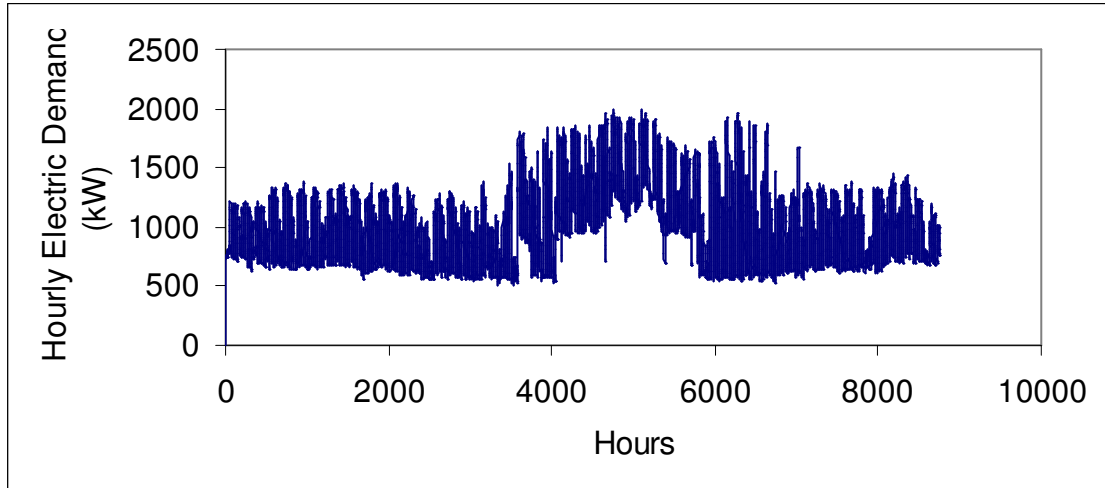

Figure 6.1: Hourly Electric Demand Profile

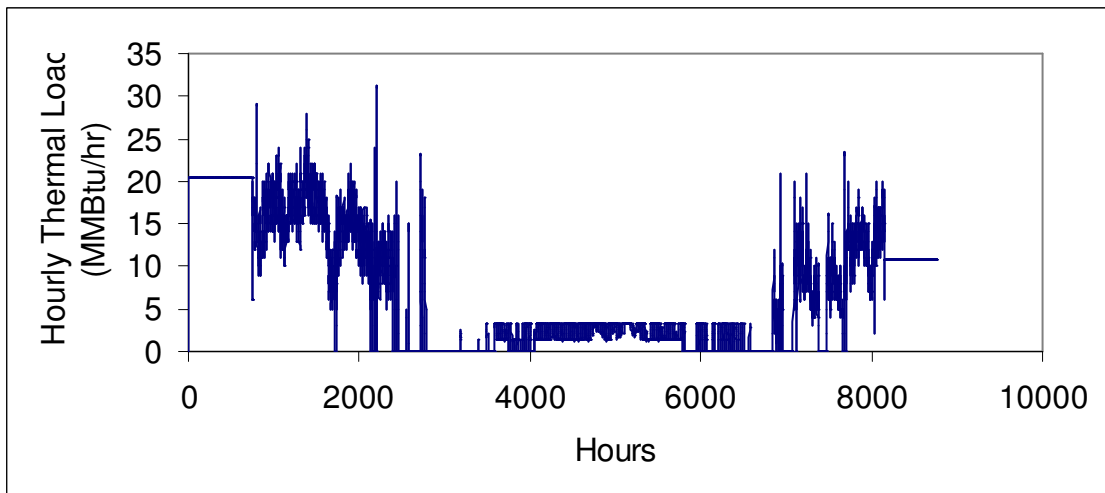

Figure 6.2: Hourly Thermal Load Profile

For this customer, by solving the optimization problem it is determined that two 600kW shall be operated onsite and producing electric power as shown in Figure 6.3.

It shall be noticed that the optimization problem explained above does not take into account the reliability of the CHP units. Thus the actual electric power generation profile of the CHP units may be different from that shown in Figure 6.3 owing to the reliability of the CHP units.

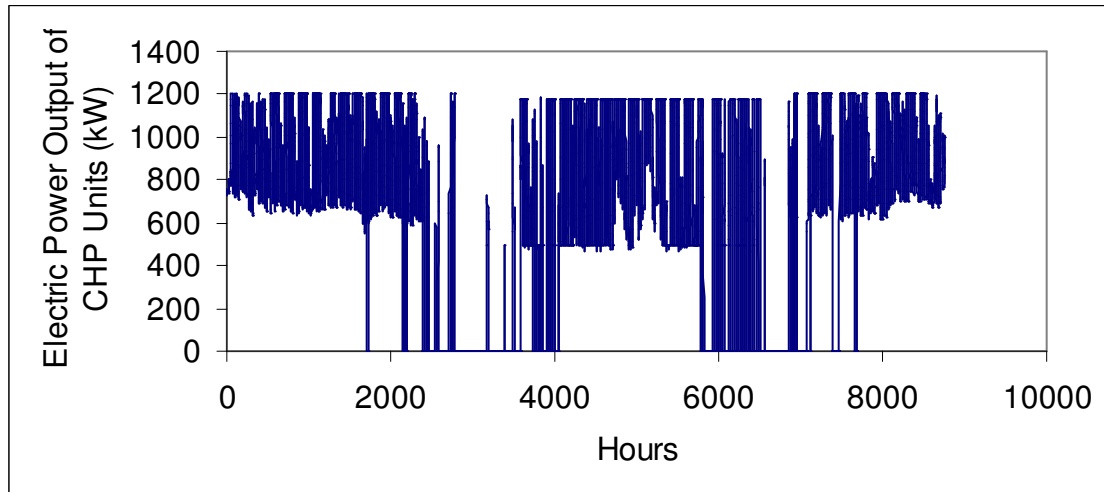

Figure 6.3: Optimal Electric Power Output of the 600kW CHP Units

In this case study an additional dimension is introduced into the optimization problem which is the reliability of the CHP units. Then the contribution of CHP units to the reliability of power supply to the customer is evaluated.

This case study consists of two experiments: Experiment 1 – two 600kW units operating at load point 9; Experiment 2 – two 190 kW units operating at load point 22. The reliability parameters for the units are listed in Table 6.1. For the purpose of these experiments, electric load profile and CHP units' electric generation profile obtained from real world customers are used.

Table 6.1: Reliability Parameters for the 600 kW and 190kW CHP Units

Unit Size (MW)	Mean Time to Failure (Hours)	Mean Time to Repair (Hours)	Scheduled Outage Factor (%)
0.600	1484.70	26.85	0.2685
0.190	850.23	25.97	0.2597

In experiment 1 the contribution of CHP units to the reliability of power supply to the customer at load point 9 is evaluated. The peak load of this customer is 1.87 MW and the average load is 1.15 MW. The size of the two CHP units that operate at this customer site is

600kW each. The hourly electric load profile and the hourly thermal load profile for this customer is shown in Figure 6.1 and Figure 6.2 respectively.

In experiment 2 the contribution of CHP units to the reliability of power supply to customer at load point 22 is evaluated. The peak load of this customer is 0.75 MW and the average load is 0.454 MW. The hourly electric demand profile for this customer is shown in Figure 6.4 and the hourly thermal load profile is shown in Figure 6.5.

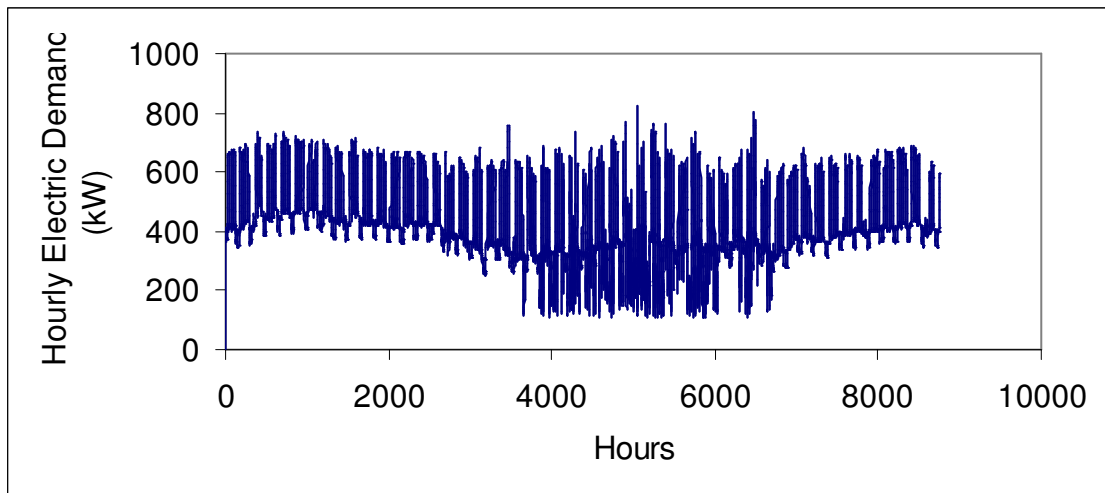

Figure 6.4: Hourly Electric Demand Profile for Customer 22

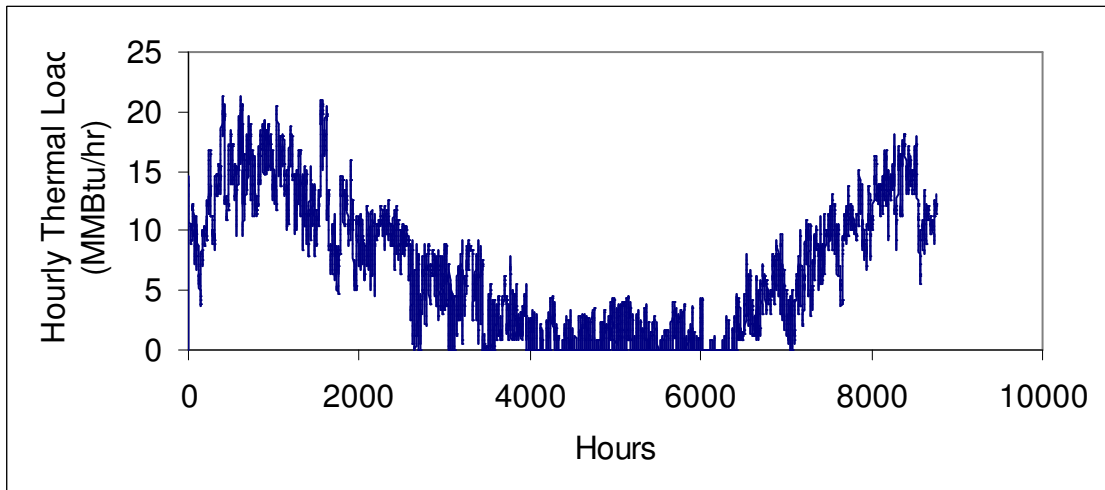

Figure 6.5: Hourly Thermal Load Profile for Customer 22

Two 190kW units are considered to operate at this customer site and the economically optimal electric generation profile of the two CHP units is shown in Figure 6.6.

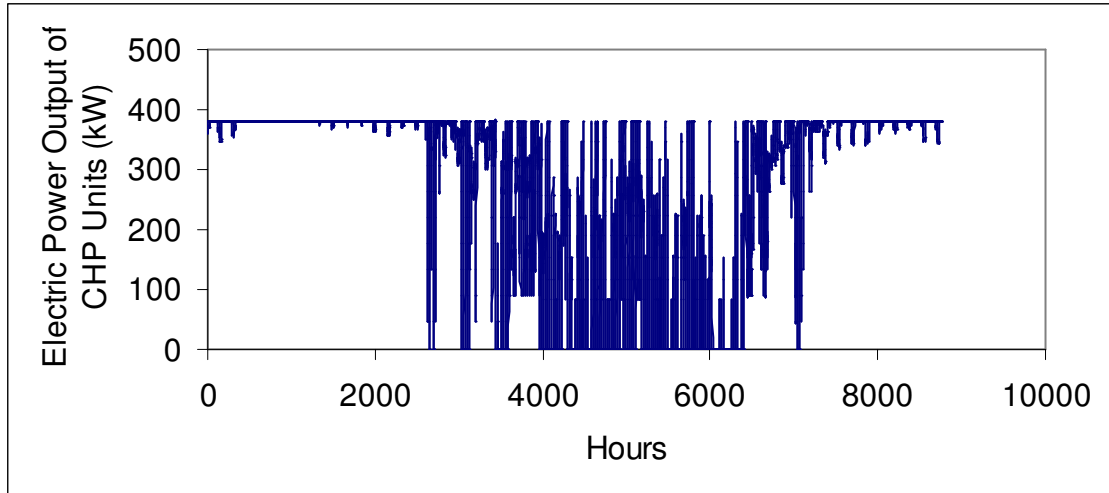

Figure 6.6: Optimal Electric Power Output of the 190 kW CHP Units

Each experiment consists of two phases. In Phase I the ideal case, that is, the contribution of three CHP units, whose operation is determined only by the reliability parameters, is evaluated. In Phase II the contribution of the economically optimal CHP units is evaluated while including the reliability of the units in the evaluation process. The details of the experiments are summarized in Table 6.2.

Table 6.2: Details of the Experiments - Case Study 7

	Experiment 1	Experiment 2
Phase I (Ideal Case)	Three 625 kW units are operated by customer 9. The generation profile of the units is based on the reliability parameters.	Three 250 kW units are operated by customer 22. The generation profile of the units is based on the reliability parameters.
Phase II (Practical Case)	Two 600kW units are operated by customer 9. The generation profile of the units is based on the economically optimal strategy and the reliability parameters of the units.	Two 190 kW units are operated by customer 22. The generation profile of the units is based on the economically optimal strategy and the reliability parameters of the units.

Results

For experiment 1, the AENS for customer 9 without any CHP units operating onsite is found to be 1.12927 MWh/yr. This represents a reliability of 99.9888%. For experiment 2, the AENS for customer 22 without any CHP units operating onsite is found to be 0.51999 MWh/yr. This represents a reliability of 99.9870%. The results of the experiments are shown in Table 6.3. The system reliability indices are summarized in Table 6.4.

Table 6.3: Results for Experiments of Case Study 7

	Experiment 1 – Customer 9			Experiment 2 – Customer 22		
	AENS (MWh/yr)	Percentage Reliability	Percentage Improvement in Reliability	LOEE (MWh/yr)	Percentage Reliability	Percentage Improvement in Reliability
Phase I (Ideal Case)	0.00753	99.99993	99.33	0.00739	99.99981	98.58
Phase II (Practical Case)	0.32933	99.99672	70.84	0.21326	99.99462	58.99

Table 6.4: LOEE Results for Experiments of Case Study 7

	Experiment 1			Experiment 2		
	LOEE (MWh/yr)	Percentage Reliability	Percentage Improvement in Reliability	LOEE (MWh/yr)	Percentage Reliability	Percentage Improvement in Reliability
Without DG Units	12.4980	99.9884	-	12.55469	99.98831	-
Phase I (Ideal Case)	11.1094	99.9897	11.11	12.17977	99.98866	2.99
Phase II (Practical Case)	11.8887	99.9889	4.88	12.19475	99.98864	2.87

From Table 6.3 it shall be observed that contribution of CHP units to the reliability of power supply to the customer is greater in the ideal case (Phase I) than that in the practical case (Phase II). This is because in the practical scenario an additional constraint is applied to the operation of the CHP units which is the economically optimal strategy.

It might appear that the customer should add more CHP capacity to improve the reliability. However, the cost of (un)reliability, that is, the cost of Energy Not Supplied, as perceived by the customer may be lesser than the cost of installing and operating additional CHP capacity. Thus, during the planning stage of CHP capacity addition to a customer site, the reliability parameters of the CHP units and the economically optimum operational strategy of CHP generation should be considered simultaneously.

CHAPTER 7

CONCLUSION

7.1 Summary

From the results obtained, it can be concluded that DG units, in particular, CHP units, enhance the reliability of the IEEE – Reliability Busbar Test System, even though individual reliabilities of the CHP units are not attractive. The following summarizes the work done towards achieving the objectives of the thesis:

- (1) The generation and distribution systems of a power grid were modeled using Monte Carlo Simulations. The systems are based on the IEEE – RTS and the IEEE – RBTS. The system was modeled such that the power generated and load on the network vary by a certain percentage for each experiment, to include real world uncertainties. Each distribution line (components that connect a load point to a supply point) is modeled as a two-state system. In distribution system modeling, the reliabilities of its components, such as lines, transformers and breakers were taken into account. The reliability parameters for a distribution line were calculated from the reliability parameters of its components. The CHP units are modeled as four-state systems. Various case studies, each case study consisting of one or more phases, were conducted. In case study 1, the modeling of the distribution system is validated. In case study 2, a previous claim regarding the optimum number of CHP units that shall be installed at a customer site was verified, In case studies 3 and 4, the contribution of CHP units to system reliability and customer reliability were evaluated. In case study 5, a methodology to determine the optimal location for installing a CHP unit in the distribution system is demonstrated. In

Chapter 6 an additional dimension is included in the evaluation of contribution of CHP units to the system reliability. This dimension is the economically optimal size and operation of the CHP units.

- (2) It was observed that the reliability of power supply to a load point decreases as the distance of the load point from the supply point and the number of components that connect the load point to the supply point increases.
- (3) For the case where the CHP units do not export power to the grid, the optimum number of CHP units that shall be installed at a customer site is verified to be three. The sum of the capacities of the CHP units should be equal to the customer peak load. For example, the optimum capacity each CHP unit for a customer with peak load of 750 kW is 250 kW.
- (4) CHP units contribute, significantly, to both system reliability and customer reliability. Customers can experience more than 99.99% reliability by installing CHP units. The improvement in system reliability is found to be directly proportional to the total installed capacity of CHP units in the distribution system.
- (5) The rate of percentage improvement in system reliability and the reliability of power supply to customers are found to be decreasing with increase in installed CHP capacity in the distribution system.
- (6) The optimal location for installing CHP units is found to be function of the customers distance from the supply point and the reliability of the components that connect the customer to the supply point.
- (7) The percentage improvement in reliability of power supply to customers and the overall system reliability is found to be lesser when the additional constraint, which is when the

CHP units are sized and operated based on an economically optimum strategy, is included in reliability evaluation.

- (8) Finally it can be concluded that the modeling of various systems and the method of reliability evaluation presented in this thesis are an effective tool for the quantitative evaluation of system and customer reliability. The method can aid in making decisions regarding the number and location of CHP units in a distribution system. Use of the modeling technique shown in this work especially that of the distribution system can help to compare the reliabilities of distribution systems and to evaluate and compare the contribution of CHP units to the system. The reliability assessment techniques demonstrated in this thesis can be used as a reliable tool for evaluating various options during the planning or capacity addition stage.
- (9) It should be noted that as this analysis is done considering the IEEE-RTS and IEEE – RBTS as the base systems, the results cannot be claimed as true representations of actual system benefits that can be obtained by implementation of CHP units. The IEEE-RTS though very comprehensive in nature does not represent a very stable/robust system. Thus for a more realistic analysis of system benefits using distributed generation, better data and information from the concerned utilities/departments is needed.

7.2 Future Work

- (1) The modeling of the power grid in this thesis includes only generation system modeling and distribution modeling. A future step could be inclusion of transmission network which would result in a complete tool for evaluation of power grid.

- (2) The analysis currently deals with CHP systems only. A future step could be to collect data for other systems like wind turbines, fuel cells, solar systems etc. and include these in the model.
- (3) A user interface for the program could aid in easier use of the model.
- (4) The algorithm used to determine the optimal location of CHP units should be improved to include the varying number of components that may be present in the distribution line which connects the supply point and the customers that are being compared.
- (5) There are several disadvantages of distributed generation cited by critics, one of them being voltage fluctuations due to uncertain and random nature of DG usage from the utility's perspective. The model presented in this thesis essentially calculates adequacy of the system; the ability of the system to supply the energy needed from it. The system security assessment – to evaluate the system response to dynamic and /or transient disturbances within the system, is not included in the model. Future work should potentially include a system security calculation by analyzing the effects on the system during component state transitions.
- (6) The model does not simulate weather conditions, seasonal changes (except for customer load). Steps may be undertaken to model the distribution system based on weather and seasonal changes.
- (7) The modeling of the distribution system is done by treating the system as a radial network. Other forms of distribution systems such as parallel network and meshed networks may be considered for reliability evaluation in the future.

APPENDIX A

DETAILS OF IEEE-RELIABILITY TEST SYSTEM

The line diagram of the IEEE-RTS is shown in Figure A.1.

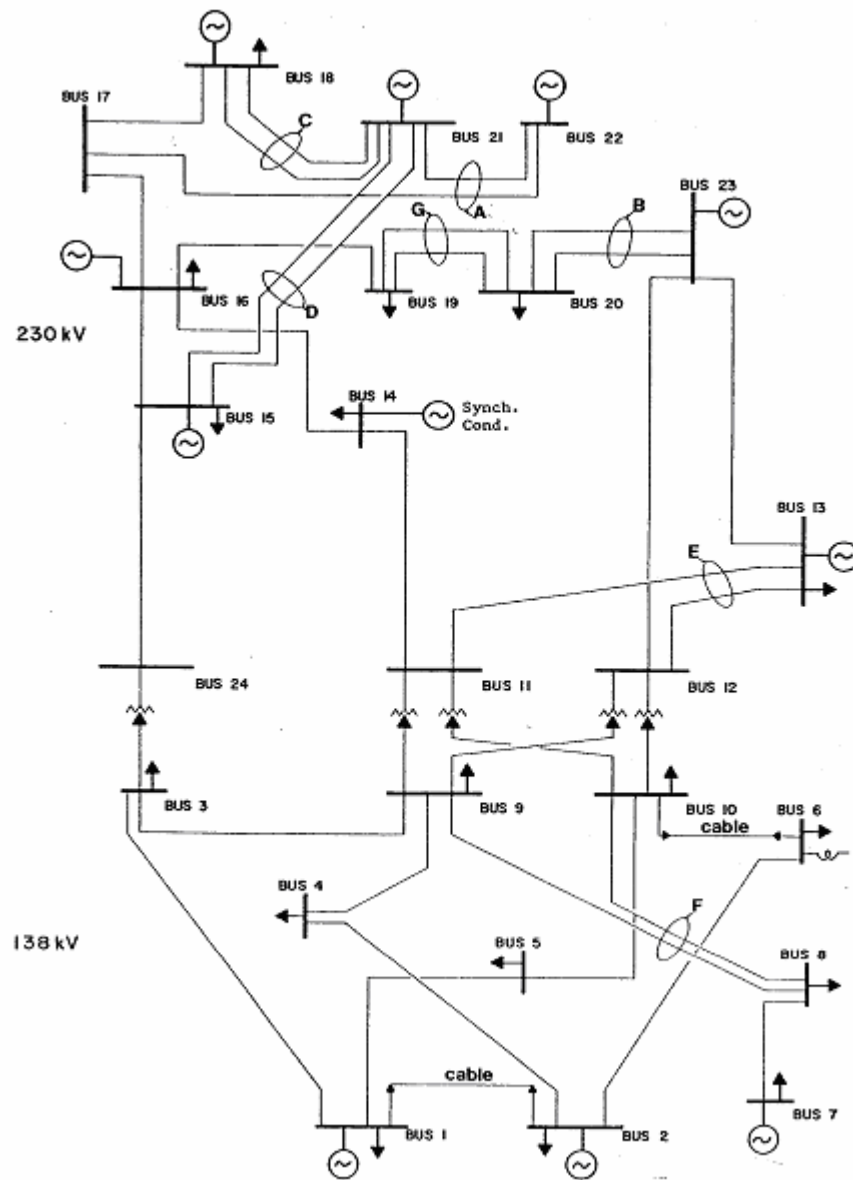

Figure A.1: IEEE – Reliability Test System

Table A.1 shows the reliability parameters for the generating units in the IEEE-RTS.

Table A.1: IEEE – RTS Data for Centrally Controlled Generating Units

Unit Size (MW)	Number of Units	Mean Time to Failure (Hours)	Mean Time to Repair (Hours)	Scheduled Outage Factor (%)
12	5	2940	60	0.16
20	4	450	50	0.16
50	6	1980	20	0.16
76	4	1960	40	0.24
100	3	1200	50	0.24
155	4	960	40	0.32
197	3	950	50	0.32
350	1	1150	100	0.4
400	2	1100	150	0.48

The basic annual peak load for the RTS is 2,850 MW. Table A.2 gives data on weekly peak loads in percentage of the annual peak load. Table A.3 gives a daily peak load cycle, in percentage of the weekly peak. The same weekly peak load cycle is assumed to apply for all seasons. Table A.4 gives weekday and weekend hourly load models for each of the three seasons. Combination of Tables A.2, A.3 and A.4 with the annual peak load defines an hourly load model of 8736 hours.

Table A.2: Weekly Peak Load in Percentage of Annual Peak

Week	Peak	Week	Peak	Week	Peak	Week	Peak
1	86.2	14	75.0	27	75.5	40	72.4
2	90.0	15	72.1	28	81.6	41	74.3
3	87.8	16	80.0	29	80.1	42	74.4
4	83.4	17	75.4	30	88.0	43	80.0
5	88.0	18	83.7	31	72.2	44	88.1
6	84.1	19	87.0	32	77.6	45	88.5
7	83.2	20	88.0	33	80.0	46	90.9
8	80.6	21	85.6	34	72.9	47	94.0
9	74.0	22	81.1	35	72.6	48	89.0
10	73.7	23	90.0	36	70.5	49	94.2
11	71.5	24	88.7	37	78.0	50	97.0
12	72.7	25	89.6	38	69.5	51	100.0
13	70.4	26	86.1	39	72.4	52	95.2

Table A.3: Daily Peak Load in Percent of Weekly Peak

Day	Peak Load
Monday	93
Tuesday	100
Wednesday	98
Thursday	96
Friday	94
Saturday	77
Sunday	75

Table A.4: Weekly Peak Load in Percentage of Annual Peak

Hour	Winter Week 1-8 & 44-52		Summer Weeks 18-30		Spring/Fall Weeks 9-17 & 31-43	
	Weekday	Weekend	Weekday	Weekend	Weekday	Weekend
12-1 a.m.	67	78	64	74	63	75
1-2	63	72	60	70	62	73
2-3	60	68	58	66	60	69
3-4	59	66	56	65	58	66
4-5	59	64	56	64	59	65
5-6	60	65	58	62	65	65
6-7	74	66	64	62	72	68
7-8	86	70	76	66	85	74
8-9	95	80	87	81	95	83
9-10	96	88	95	86	99	89
10-11	96	90	99	91	100	92
11-Noon	95	91	100	93	99	94
Noon-1 p.m.	95	90	99	93	93	91
1-2	95	88	100	92	92	90
2-3	93	87	100	91	90	90
3-4	94	87	97	91	88	86
4-5	99	91	96	92	90	85
5-6	100	100	96	94	92	88
6-7	100	99	93	95	96	92
7-8	96	97	92	95	98	100
8-9	91	94	92	100	96	97
9-10	83	92	93	93	90	95
10-11	73	87	87	88	80	90
11-12	63	81	72	80	70	85

APPENDIX B

DETAILS OF IEEE-RELIABILITY BUSBAR TEST SYSTEM

The line diagram of the IEEE-RBTS is shown in Figure B.1.

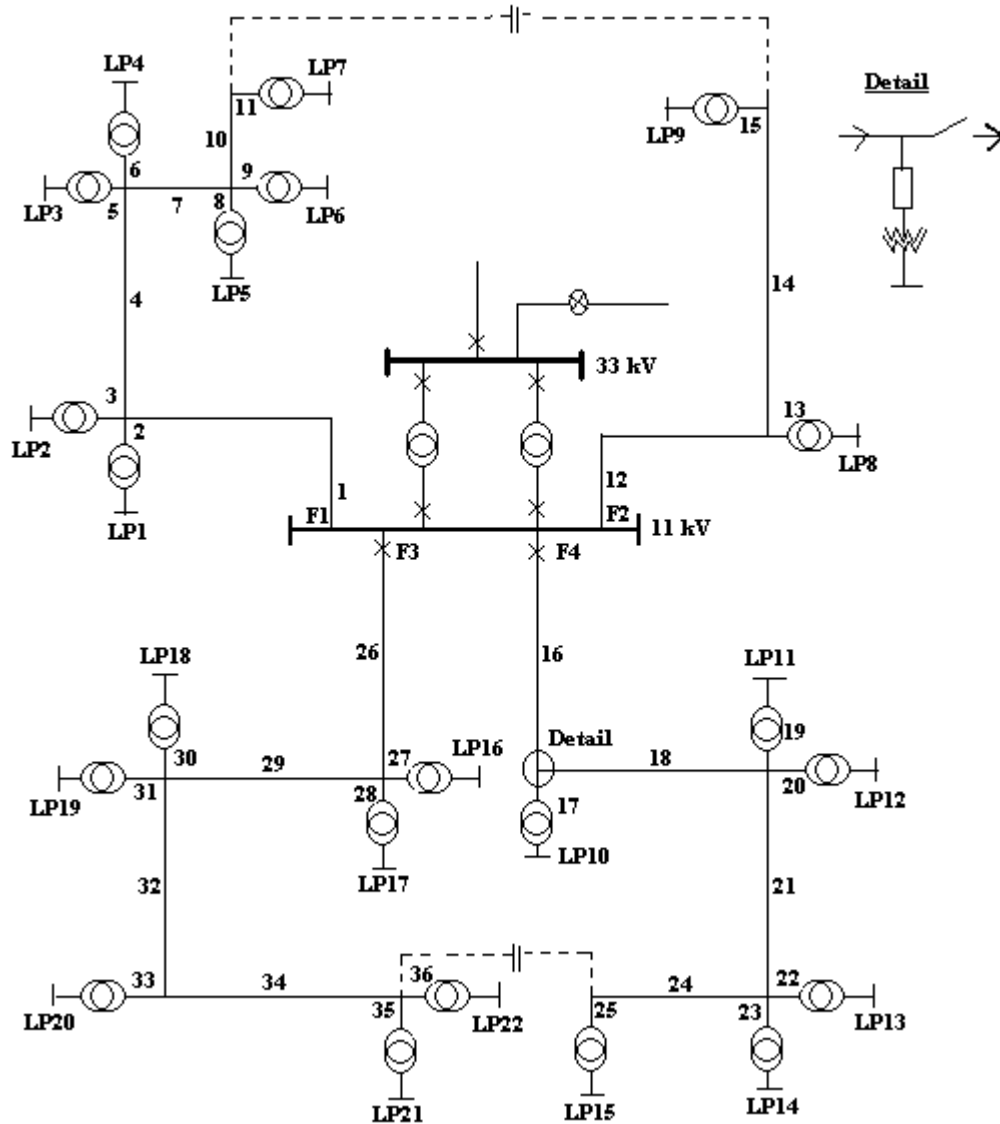

Figure B.1: Distribution System of Busbar 2 - IEEE-Reliability Busbar Test System

Table B.1: Average and Peak Load of Customers at Various Load Points of the Distribution System.

Customer at Load Point	Average Load (MW)	Peak Load (MW)
1	0.535	0.8668
2	0.535	0.8668
3	0.535	0.8668
4	0.566	0.9167
5	0.566	0.9167
6	0.454	0.7500
7	0.454	0.7500
8	1.000	1.6279
9	1.150	1.8721
10	0.535	0.8668
11	0.535	0.8668
12	0.450	0.7291
13	0.566	0.9167
14	0.566	0.9167
15	0.454	0.7500
16	0.454	0.7500
17	0.450	0.7291
18	0.450	0.7291
19	0.450	0.7291
20	0.566	0.9167
21	0.566	0.9167
22	0.454	0.7500

Table B.2: Reliability Parameters of Distribution System Components

Component	Failure Rate (failures/year)	Repair Time (hours)
Lines (per km)	0.065	5
Breaker - 11 kV	0.006	4
Breaker - 33 kV	0.002	4
Breaker - 138 kV	0.0058	8
Transformer (11/0.415)	0.015	200
Transformer (33/11)	0.015	120
Transformer (138/33)	0.01	168
11 kV busbar	0.001	2
33 kV busbar	0.001	2

The following charts, in order, represent the customer hourly load profiles for the 22 load points in the bus 2 of IEEE – RBTS.

Customer 1: Peak Load = 0.8668 MW; Average Load = 0.535 MW

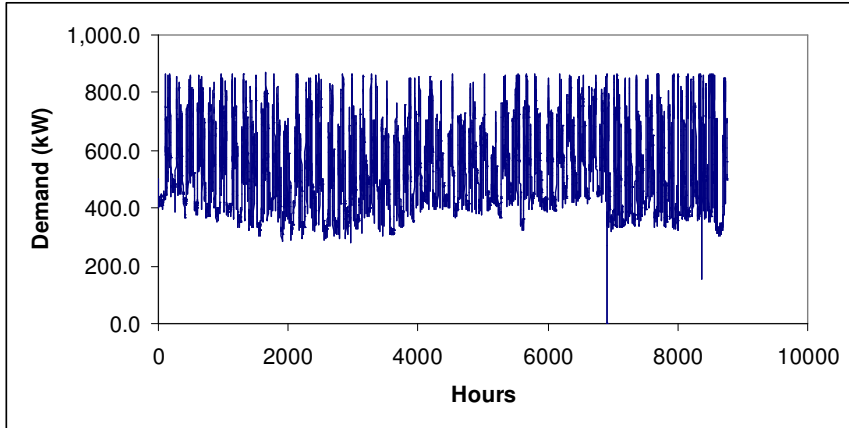

Figure B.2: Hourly Load Profile of Customer 1

Customer 2: Peak Load = 0.8668 MW; Average Load = 0.535 MW

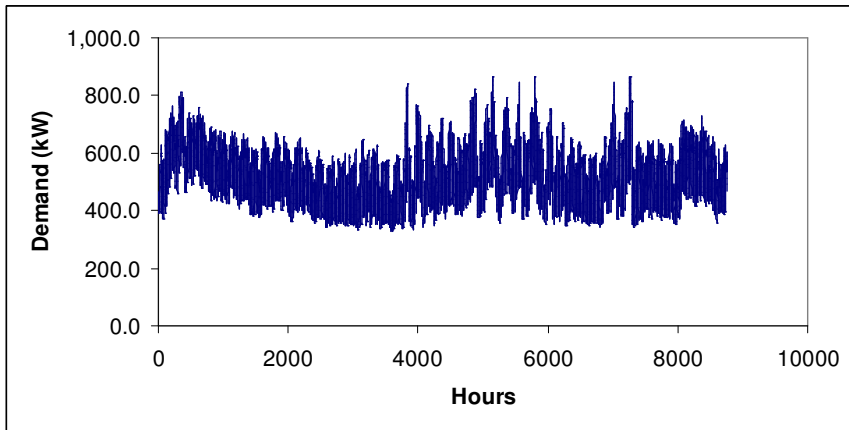

Figure B.3: Hourly Load Profile of Customer 2

Customer 3: Peak Load = 0.8668 MW; Average Load = 0.535 MW

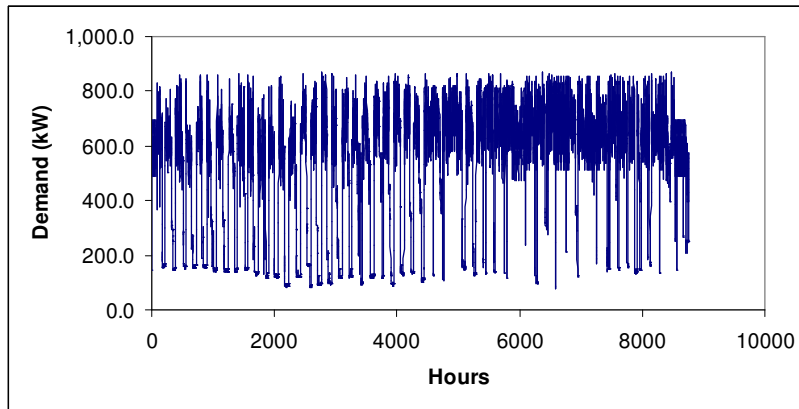

Figure B.4: Hourly Load Profile of Customer 3

Customer 4: Peak Load = 0.9167 MW; Average Load = 0.566 MW

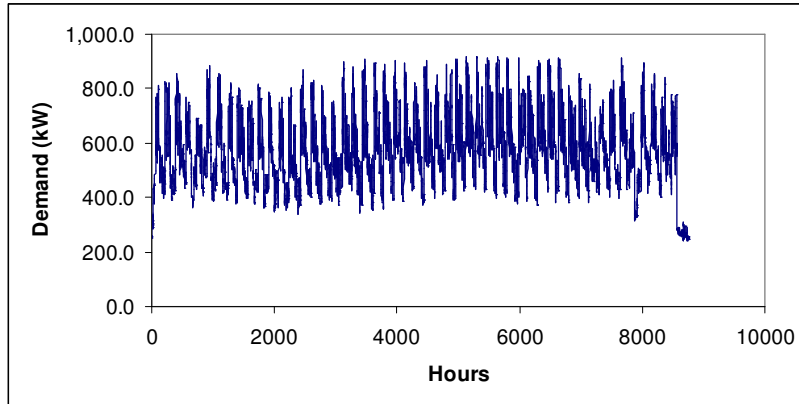

Figure B.5: Hourly Load Profile of Customer 4

Customer 5: Peak Load = 0.9167 MW; Average Load = 0.566 MW

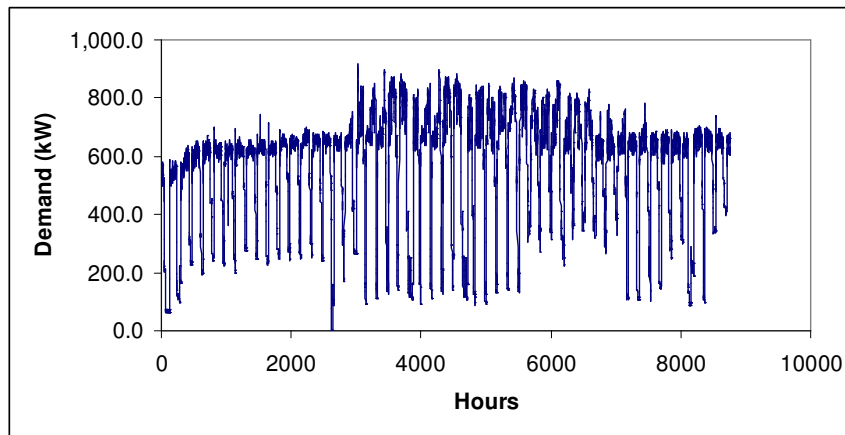

Figure B.6: Hourly Load Profile of Customer 5

Customer 6: Peak Load = 0.750 MW; Average Load = 0.454 MW

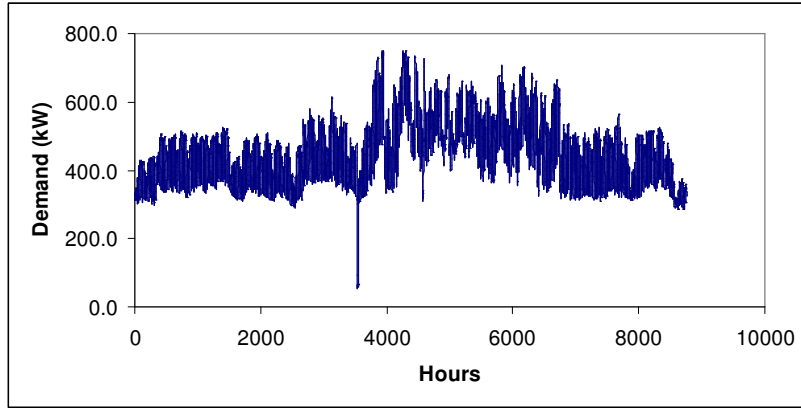

Figure B.7: Hourly Load Profile of Customer 6

Customer 7: Peak Load = 0.750 MW; Average Load = 0.454 MW

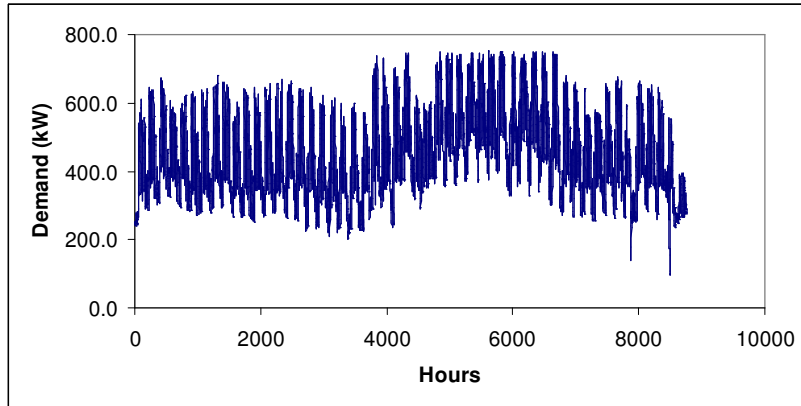

Figure B.8: Hourly Load Profile of Customer 7

Customer 8: Peak Load = 1.6279 MW; Average Load = 1.00 MW

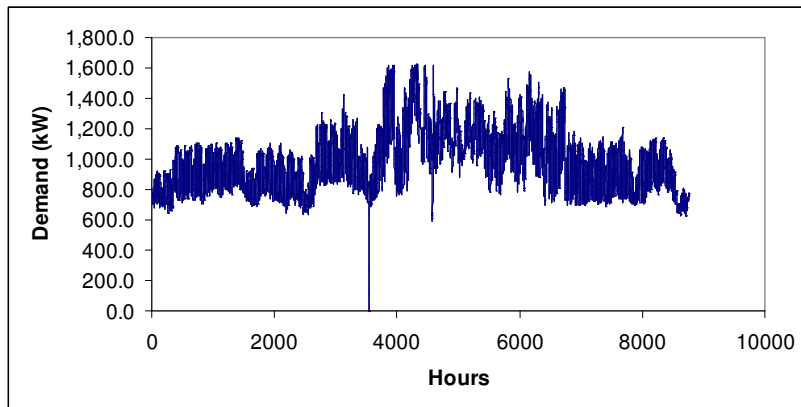

Figure B.9: Hourly Load Profile of Customer 8

Customer 9: Peak Load = 1.8721 MW; Average Load = 1.15 MW

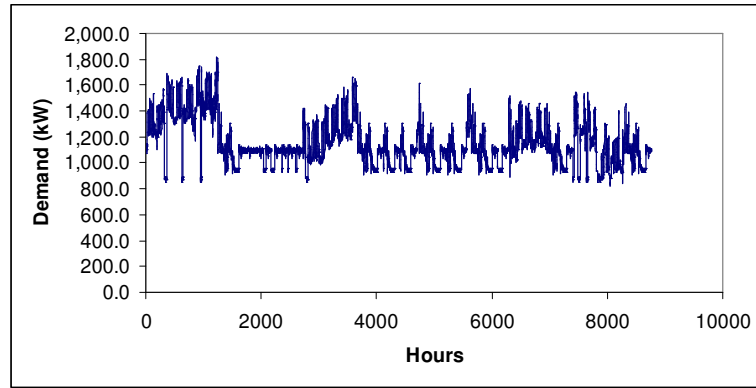

Figure B.10: Hourly Load Profile of Customer 9

Customer 10: Peak Load = 0.8668 MW; Average Load = 0.535 MW

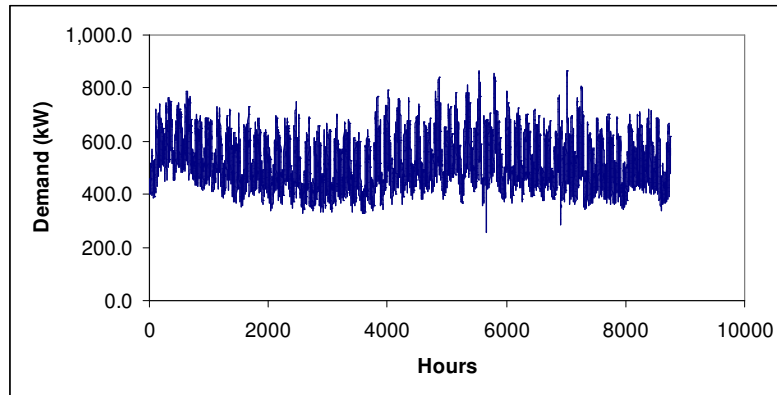

Figure B.11: Hourly Load Profile of Customer 10

Customer 11: Peak Load = 0.8668 MW; Average Load = 0.535 MW

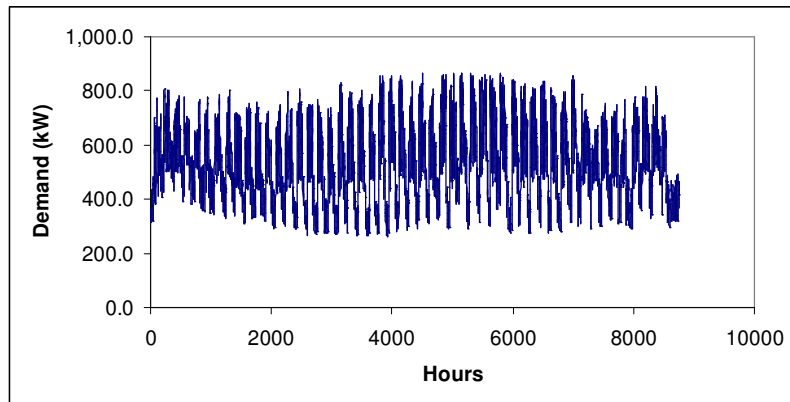

Figure B.12: Hourly Load Profile of Customer 11

Customer 12: Peak Load = 0.7291 MW; Average Load = 0.450 MW

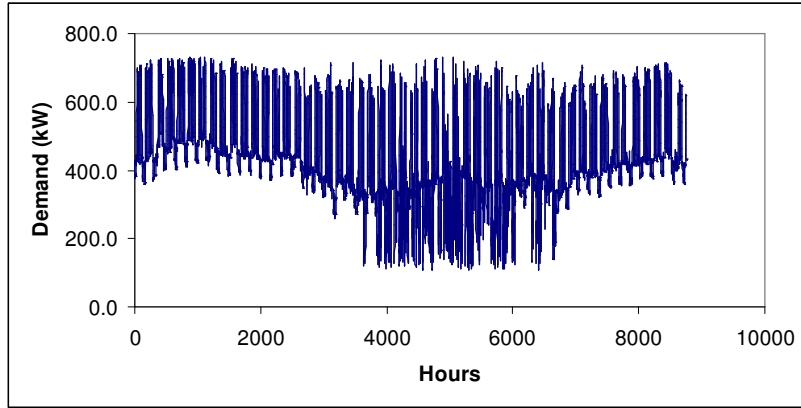

Figure B.13: Hourly Load Profile of Customer 12

Customer 13: Peak Load = 0.9167 MW; Average Load = 0.566 MW

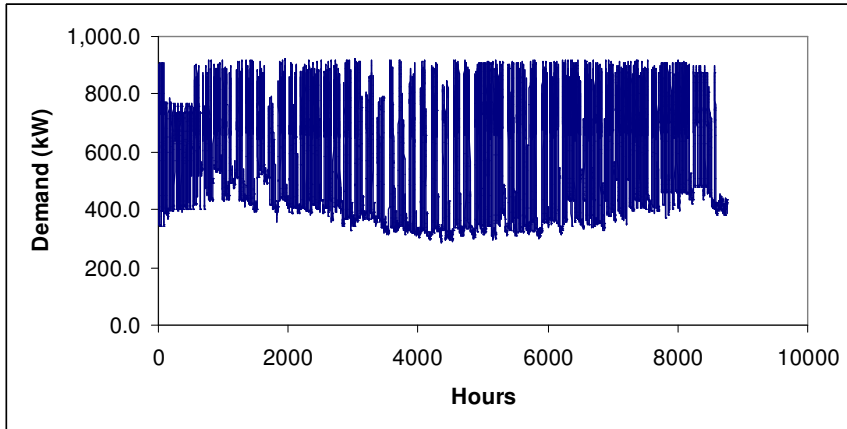

Figure B.14: Hourly Load Profile of Customer 13

Customer 14: Peak Load = 0.9167 MW; Average Load = 0.566 MW

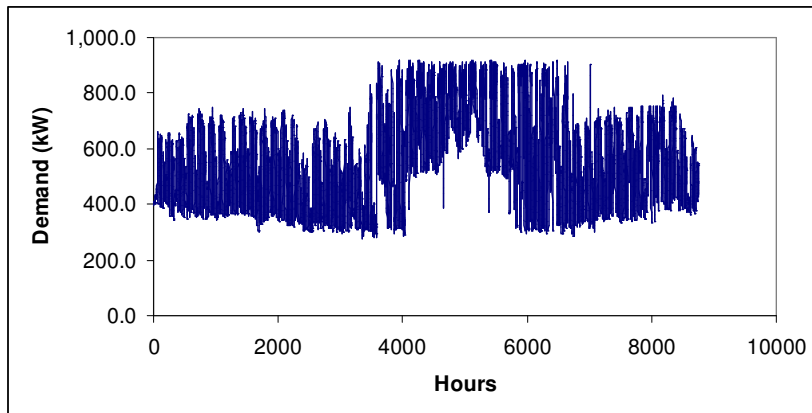

Figure B.15: Hourly Load Profile of Customer 14

Customer 15: Peak Load = 0.750 MW; Average Load = 0.454 MW

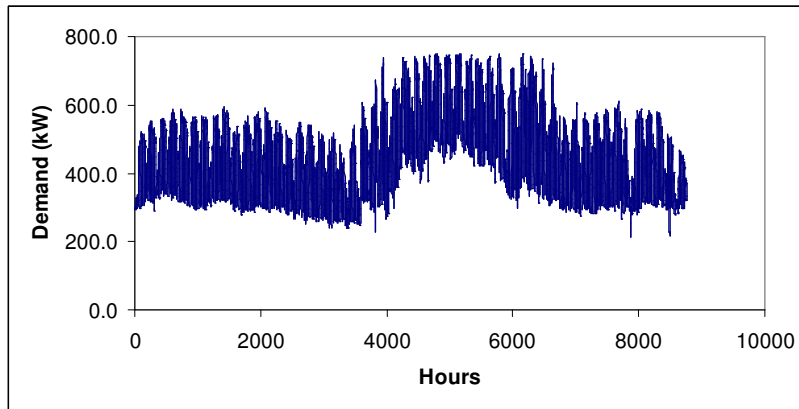

Figure B.16: Hourly Load Profile of Customer 15

Customer 16: Peak Load = 0.750 MW; Average Load = 0.454 MW

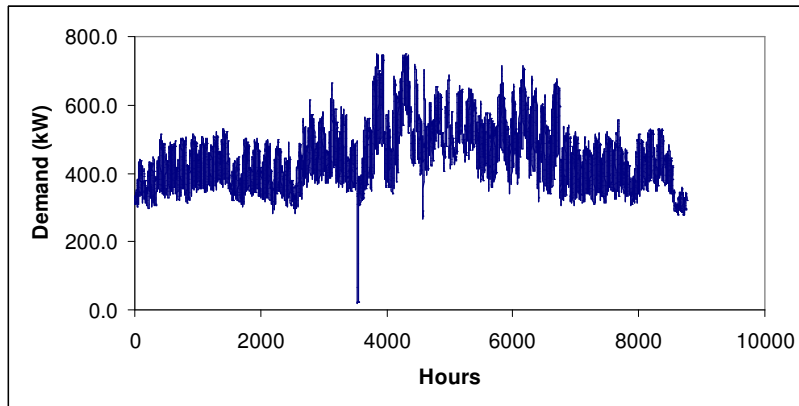

Figure B.17: Hourly Load Profile of Customer 16

Customer 17: Peak Load = 0.7291 MW; Average Load = 0.450 MW

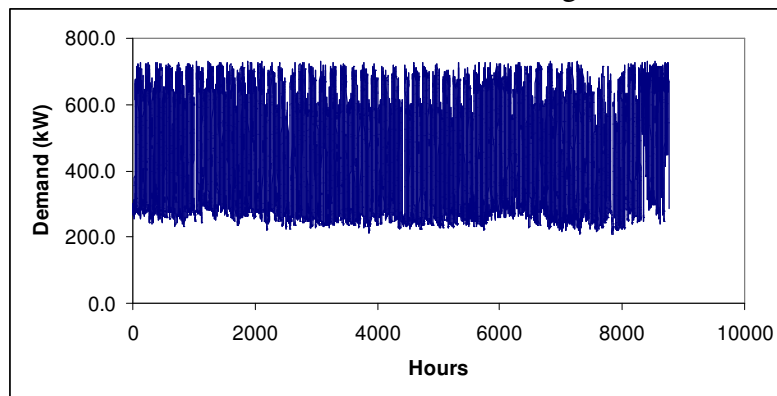

Figure B.18: Hourly Load Profile of Customer 17

Customer 18: Peak Load = 0.7291 MW; Average Load = 0.450 MW

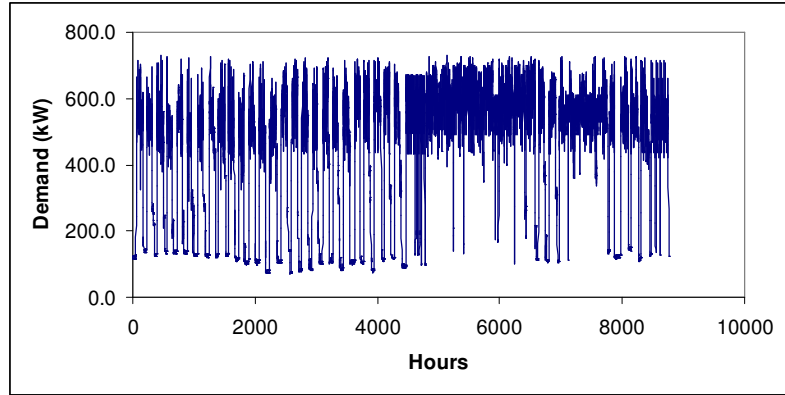

Figure B.19: Hourly Load Profile of Customer 18

Customer 19: Peak Load = 0.7291 MW; Average Load = 0.450 MW

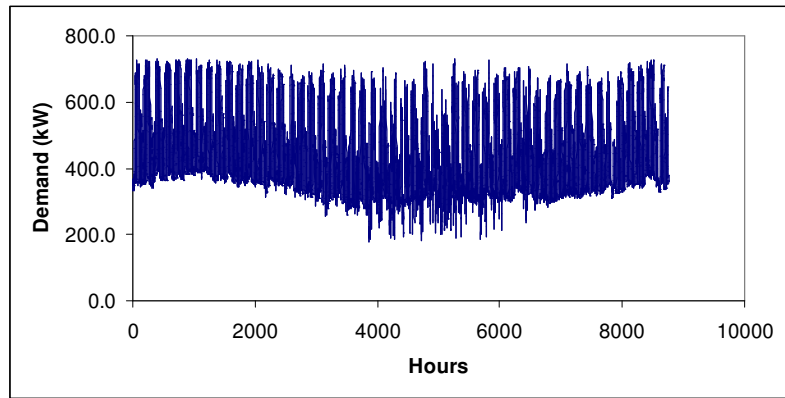

Figure B.20: Hourly Load Profile of Customer 19

Customer 20: Peak Load = 0.9167 MW; Average Load = 0.566 MW

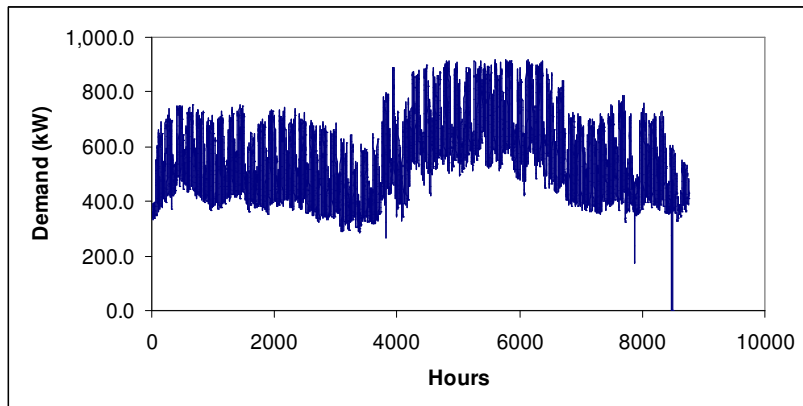

Figure B.21: Hourly Load Profile of Customer 20

Customer 21: Peak Load = 0.9167 MW; Average Load = 0.566 MW

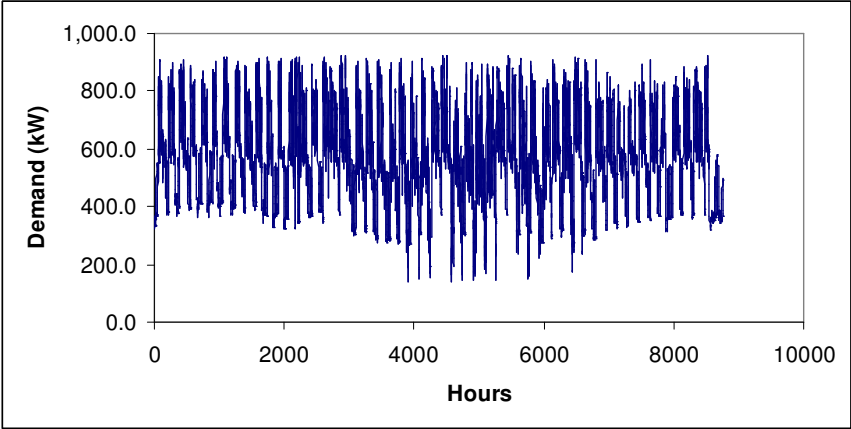

Figure B.22: Hourly Load Profile of Customer 21

Customer 22: Peak Load = 0.750 MW; Average Load = 0.454 MW

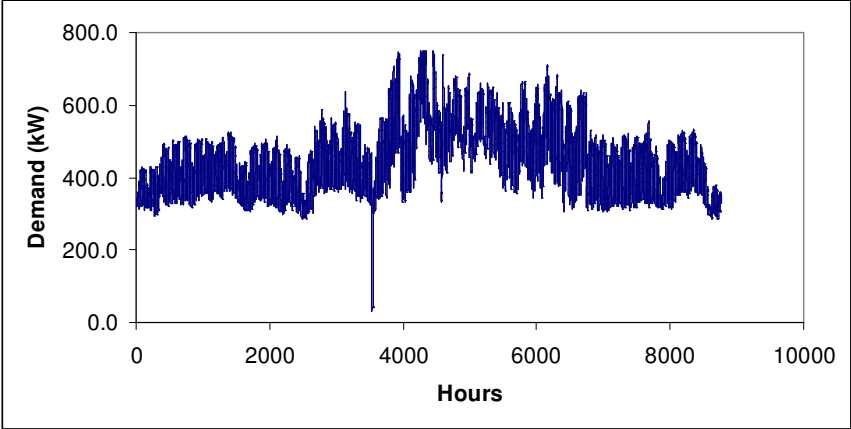

Figure B.23: Hourly Load Profile of Customer 22

The following chart shows the hourly load profile for the entire distribution system.

System Peak Load = 20 MW; Average Load = 12.219 MW

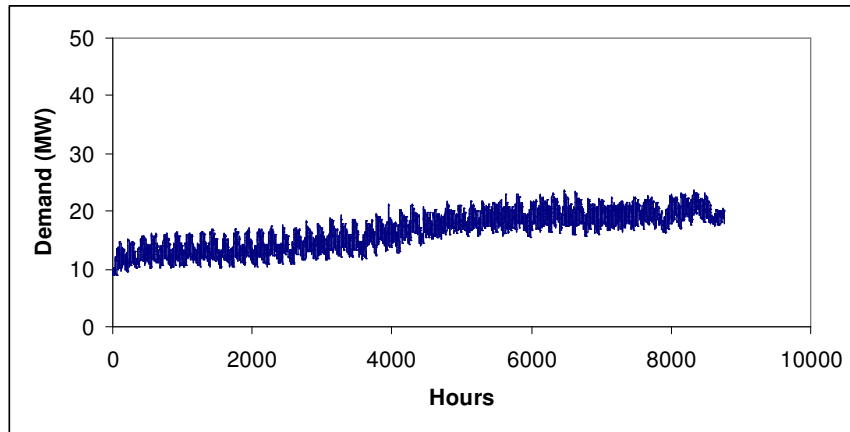

Figure B.24: Hourly Load Profile for the Distribution System at Bus 2

APPENDIX C

CHP UNIT RELIABILITY DATA

Table C.1: Reliability Parameters for CHP Units [16]

Unit Size (MW)	Mean Time to Failure (Hours)	Mean Time to Repair (Hours)	Scheduled Outage Factor (%)
0.375	1146.35	26.40	0.0020
0.250	948.04	26.11	0.0022
0.300	1028.249	26.22772	0.0021
0.325	1067.912	26.28439	0.0020
0.550	1411.577	26.75423	0.0018
0.625	1520.815	26.89477	0.0018

APPENDIX D

CALCULATION OF RELIABILITY PARAMETERS FOR THE DISTRIBUTION SYSTEM

The basic reliability parameters for the distribution line that connects each load point to the supply point is evaluated using the principle of series systems as explained in Chapter 4. The distribution system at the busbar 2 of the IEEE-RBTS is considered to operate as a radial network. The failure rate and repair time for each component in the distribution line are obtained from the IEEE-RBTS (Appendix B).

Table D.1: Calculation of Reliability Parameters for the Distribution Lines

Feeder 1	LP 1		LP 2		LP 3		LP 4	
	Failure Rate	Repair Time	Failure Rate	Repair Time	Failure Rate	Repair Time	Failure Rate	Repair Time
Section 1	0.049	5	0.049	5	0.049	5	0.049	5
Section 4	0.049	1	0.049	1	0.049	5	0.049	5
Section 7	0.049	1	0.049	1	0.049	1	0.049	1
Section 10	0.039	1	0.039	1	0.039	1	0.039	1
Distributor 2	0.039	5	-	-	-	-	-	-
Distributor 3	-	-	0.052	5	-	-	-	-
Distributor 5	-	-	-	-	0.052	5	-	-
Distributor 6	-	-	-	-	-	-	0.039	5
Distributor 8	-	-	-	-	-	-	-	-
Distributor 9	-	-	-	-	-	-	-	-
Distributor 11	-	-	-	-	-	-	-	-
Breaker (138 kV)	0.006	108	0.006	108	0.006	108	0.006	108
Transformer (138/33)	0.010	168	0.010	168	0.010	168	0.010	168
33 kV busbar	0.001	8	0.001	8	0.001	8	0.001	8
Breaker (33 kV)	0.002	96	0.002	96	0.002	96	0.002	96
Transformer (33/11)	0.015	120	0.015	120	0.015	120	0.015	120
11 kV busbar	0.001	8	0.001	8	0.001	8	0.001	8
Breakers (11 kV)	0.006	72	0.006	72	0.006	72	0.006	72
Transformer (11/0.415)	0.015	200	0.015	200	0.015	200	0.015	200
	0.280	29.71	0.293	28.62	0.293	29.28	0.280	30.41

Feeder 1	LP 5		LP 6		LP 7	
	Failure Rate	Repair Time	Failure Rate	Repair Time	Failure Rate	Repair Time
Section 1	0.049	5	0.049	5	0.049	5
Section 4	0.049	5	0.049	5	0.049	5
Section 7	0.049	5	0.049	5	0.049	5
Section 10	0.039	1	0.039	1	0.039	5
Distributor 2	-	-	-	-	-	-
Distributor 3	-	-	-	-	-	-
Distributor 5	-	-	-	-	-	-
Distributor 6	-	-	-	-	-	-
Distributor 8	0.052	5	-	-	-	-
Distributor 9	-	-	0.049	5	-	-
Distributor 11	-	-	-	-	0.052	5
Breaker (138 kV)	0.006	108	0.006	108	0.006	108
Transformer (138/33)	0.010	168	0.010	168	0.010	168
33 kV busbar	0.001	8	0.001	8	0.001	8
Breaker (33 kV)	0.002	96	0.002	96	0.002	96
Transformer (33/11)	0.015	120	0.015	120	0.015	120
11 kV busbar	0.001	8	0.001	8	0.001	8
Breakers (11 kV)	0.006	72	0.006	72	0.006	72
Transformer (11/0.415)	0.015	200	0.015	200	0.015	200
	0.293	29.95	0.290	30.23	0.293	30.48

Feeder 2	LP 8		LP 9	
	Failure Rate	Repair Time	Failure Rate	Repair Time
Section 12	0.049	5	0.049	5
Section 14	0.039	1	0.039	1
Distributor 13	0.052	5	-	-
Distributor 15	-	-	0.052	5
Breaker (138 kV)	0.006	108	0.006	108
Transformer (138/33)	0.010	168	0.010	168
33 kV busbar	0.001	8	0.001	8
Breaker (33 kV)	0.002	96	0.002	96
Transformer (33/11)	0.015	120	0.015	120
11 kV busbar	0.001	8	0.001	8
Breakers (11 kV)	0.006	72	0.006	72
Transformer (11/0.415)	0.015	200	0.015	200
	0.175	27.83	0.175	28.72

Feeder 3	LP 16		LP 17		LP 18		LP 19	
	Failure Rate	Repair Time	Failure Rate	Repair Time	Failure Rate	Repair Time	Failure Rate	Repair Time
Section 26	0.052	5	0.052	5	0.052	5	0.052	5
Section 29	0.049	1	0.049	1	0.049	5	0.049	5
Section 32	0.049	1	0.049	1	0.049	1	0.049	1
Section 34	0.039	1	0.039	1	0.039	1	0.039	1
Distributor 27	0.049	5	-	-	-	-	-	-
Distributor 28	-	-	0.039	5	-	-	-	-
Distributor 30	-	-	-	-	0.039	5	-	-
Distributor 31	-	-	-	-	-	-	0.052	5
Distributor 33	-	-	-	-	-	-	-	-
Distributor 35	-	-	-	-	-	-	-	-
Distributor 36	-	-	-	-	-	-	-	-
Breaker (138 kV)	0.006	108	0.006	108	0.006	108	0.006	108
Transformer (138/33)	0.010	168	0.010	168	0.010	168	0.010	168
33 kV busbar	0.001	8	0.001	8	0.001	8	0.001	8
Breaker (33 kV)	0.002	96	0.002	96	0.002	96	0.002	96
Transformer (33/11)	0.015	120	0.015	120	0.015	120	0.015	120
11 kV busbar	0.001	8	0.001	8	0.001	8	0.001	8
Breakers (11 kV)	0.006	72	0.006	72	0.006	72	0.006	72
Transformer (11/0.415)	0.015	200	0.015	200	0.015	200	0.015	200
	0.293	28.62	0.283	29.43	0.283	30.12	0.296	29.02

Feeder 3	LP 20		LP 21		LP 22	
	Failure Rate	Repair Time	Failure Rate	Repair Time	Failure Rate	Repair Time
Section 26	0.052	5	0.052	5	0.052	5
Section 29	0.049	5	0.049	5	0.049	5
Section 32	0.049	5	0.049	5	0.049	5
Section 34	0.039	1	0.039	5	0.039	5
Distributor 27	-	-	-	-	-	-
Distributor 28	-	-	-	-	-	-
Distributor 30	-	-	-	-	-	-
Distributor 31	-	-	-	-	-	-
Distributor 33	0.052	5	-	-	-	-
Distributor 35	-	-	0.049	5	-	-
Distributor 36	-	-	-	-	0.052	5
Breaker (138 kV)	0.006	108	0.006	108	0.006	108
Transformer (138/33)	0.010	168	0.010	168	0.010	168
33 kV busbar	0.001	8	0.001	8	0.001	8
Breaker (33 kV)	0.002	96	0.002	96	0.002	96
Transformer (33/11)	0.015	120	0.015	120	0.015	120
11 kV busbar	0.001	8	0.001	8	0.001	8
Breakers (11 kV)	0.006	72	0.006	72	0.006	72
Transformer (11/0.415)	0.015	200	0.015	200	0.015	200
	0.296	29.68	0.293	30.48	0.296	30.20

Feeder 4	LP 10		LP 11		LP 12	
	Failure Rate	Repair Time	Failure Rate	Repair Time	Failure Rate	Repair Time
Section 16	0.049	5	0.049	5	0.049	5
Section 18	0.052	1	0.052	5	0.052	5
Section 21	0.039	1	0.039	1	0.039	1
Section 24	0.049	1	0.049	1	0.049	1
Distributor 17	0.039	5	-	-	-	-
Distributor 19	-	-	0.049	5	-	-
Distributor 20	-	-	-	-	0.052	5
Distributor 22	-	-	-	-	-	-
Distributor 23	-	-	-	-	-	-
Distributor 25	-	-	-	-	-	-
Breaker (138 kV)	0.006	108	0.006	108	0.006	108
Transformer (138/33)	0.010	168	0.010	168	0.010	168
33 kV busbar	0.001	8	0.001	8	0.001	8
Breaker (33 kV)	0.002	96	0.002	96	0.002	96
Transformer (33/11)	0.015	120	0.015	120	0.015	120
11 kV busbar	0.001	8	0.001	8	0.001	8
Breakers (11 kV)	0.006	72	0.006	72	0.006	72
Transformer (11/0.415)	0.015	200	0.015	200	0.015	200
	0.283	29.39	0.293	29.28	0.296	29.02

Feeder 4	LP 13		LP 14		LP 15	
	Failure Rate	Repair Time	Failure Rate	Repair Time	Failure Rate	Repair Time
Section 16	0.049	5	0.049	5	0.049	5
Section 18	0.052	5	0.052	5	0.052	5
Section 21	0.039	5	0.039	5	0.039	5
Section 24	0.049	1	0.049	1	0.049	5
Distributor 17	-	-	-	-	-	-
Distributor 19	-	-	-	-	-	-
Distributor 20	-	-	-	-	-	-
Distributor 22	0.049	5	-	-	-	-
Distributor 23	-	-	0.052	5	-	-
Distributor 25	-	-	-	-	0.039	5
Breaker (138 kV)	0.006	108	0.006	108	0.006	108
Transformer (138/33)	0.010	168	0.010	168	0.010	168
33 kV busbar	0.001	8	0.001	8	0.001	8
Breaker (33 kV)	0.002	96	0.002	96	0.002	96
Transformer (33/11)	0.015	120	0.015	120	0.015	120
11 kV busbar	0.001	8	0.001	8	0.001	8
Breakers (11 kV)	0.006	72	0.006	72	0.006	72
Transformer (11/0.415)	0.015	200	0.015	200	0.015	200
	0.293	29.82	0.296	29.54	0.283	31.36

APPENDIX E

RESULTS OF CASE STUDY 3

The results obtained in case study 3 were discussed in section 5.4. Here the AENS values for all the customers obtained in each experiment are listed.

Table E.1: Case Study 3 Experiment 1 Results - 8% of the Load Supplied by CHP units

Customer at Load Point	AENS – Phase I (MWh/year)	AENS – Phase II (MWh/year)	Percentage Improvement in Reliability (%)
1	0.525035	0.47707	9.13577
2	0.579613	0.52642	9.17664
3	0.530853	0.48108	9.37623
4	0.56002	0.50455	9.90518
5	0.578274	0.52931	8.46657
6	0.468441	0.42612	9.03486
7	0.441398	0.39676	10.11196
8	1.00807	0.01075	98.93410
9	1.16248	1.05252	9.45874
10	0.553595	0.49954	9.76400
11	0.541097	0.48886	9.65465
12	0.54656	0.49441	9.54186
13	0.681466	0.61529	9.71142
14	0.635539	0.57478	9.56039
15	0.480154	0.43452	9.50341
16	0.454734	0.41028	9.77517
17	0.546389	0.49363	9.65612
18	0.390251	0.35292	9.56589
19	0.551137	0.49089	10.93086
20	0.563799	0.51205	9.17845
21	0.592805	0.53402	9.91608
22	0.47917	0.43692	8.81691

Table E.2: Case Study 3 Experiment 2 Results – 15.5% of the Load Supplied by CHP units

Customer at Load Point	AENS – Phase I (MWh/year)	AENS – Phase II (MWh/year)	Percentage Improvement in Reliability (%)
1	0.525035	0.47298	9.91390
2	0.579613	0.52184	9.96690
3	0.530853	0.47703	10.13943
4	0.56002	0.50024	10.67452
5	0.578274	0.52491	9.22823
6	0.468441	0.42252	9.80197
7	0.441398	0.39345	10.86354
8	1.00807	0.01061	98.94739
9	1.16248	1.04341	10.24305
10	0.553595	0.49519	10.54949
11	0.541097	0.48469	10.42539
12	0.54656	0.01850	96.61512
13	0.681466	0.60990	10.50111
14	0.635539	0.56985	10.33571
15	0.480154	0.43083	10.27284
16	0.454734	0.00617	98.64374
17	0.546389	0.48918	10.47046
18	0.390251	0.34999	10.31732
19	0.551137	0.48652	11.72367
20	0.563799	0.50776	9.94033
21	0.592805	0.52958	10.66531
22	0.47917	0.43325	9.58354

Table E.3: Case Study 3 Experiment 3 Results - 25% of the Load Supplied by CHP units

Customer at Load Point	AENS – Phase I (MWh/year)	AENS – Phase II (MWh/year)	Percentage Improvement in Reliability (%)
1	0.525035	0.46792	10.87882
2	0.579613	0.51616	10.94776
3	0.530853	0.47201	11.08473
4	0.56002	0.49490	11.62881
5	0.578274	0.51944	10.17332
6	0.468441	0.41808	10.75005
7	0.441398	0.38936	11.78950
8	1.00807	0.01047	98.96168
9	1.16248	0.01100	99.05384
10	0.553595	0.48980	11.52388
11	0.541097	0.47952	11.38089
12	0.54656	0.01850	96.61519
13	0.681466	0.60320	11.48548
14	0.635539	0.56372	11.30043
15	0.480154	0.42626	11.22382
16	0.454734	0.00615	98.64788
17	0.546389	0.48365	11.48260
18	0.390251	0.34639	11.23883
19	0.551137	0.48109	12.70948
20	0.563799	0.50243	10.88555
21	0.592805	0.52406	11.59667
22	0.47917	0.42871	10.53147

Table E.4: Case Study 3 Experiment 4 Results – 48.4% of the Load Supplied by CHP units

Customer at Load Point	AENS – Phase I (MWh/year)	AENS – Phase II (MWh/year)	Percentage Improvement in Reliability (%)
1	0.525035	0.45546	13.25111
2	0.579613	0.50219	13.35839
3	0.530853	0.45967	13.41011
4	0.56002	0.48177	13.97342
5	0.578274	0.50600	12.49753
6	0.468441	0.00603	98.71181
7	0.441398	0.37928	14.07210
8	1.00807	0.01034	98.97438
9	1.16248	0.01114	99.04176
10	0.553595	0.00648	98.83012
11	0.541097	0.00755	98.60399
12	0.54656	0.01793	96.71937
13	0.681466	0.58675	13.89930
14	0.635539	0.54868	13.66714
15	0.480154	0.41502	13.56481
16	0.454734	0.00574	98.73762
17	0.546389	0.02092	96.17207
18	0.390251	0.33751	13.51540
19	0.551137	0.01777	96.77626
20	0.563799	0.48933	13.20789
21	0.592805	0.51051	13.88314
22	0.47917	0.00706	98.52701

Table E.5: Case Study 3 Experiment 5 Results – 73.3% of the Load Supplied by CHP units

Customer at Load Point	AENS – Phase I (MWh/year)	AENS – Phase II (MWh/year)	Percentage Improvement in Reliability (%)
1	0.525035	0.01569	97.01182
2	0.579613	0.01675	97.10980
3	0.530853	0.01786	96.63636
4	0.56002	0.01855	96.68833
5	0.578274	0.50600	12.49821
6	0.468441	0.00598	98.72343
7	0.441398	0.12879	70.82227
8	1.00807	0.01021	98.98707
9	1.16248	0.01100	99.05384
10	0.553595	0.00644	98.83678
11	0.541097	0.00710	98.68785
12	0.54656	0.01792	96.72131
13	0.681466	0.58750	13.78880
14	0.635539	0.54790	13.78971
15	0.480154	0.41440	13.69436
16	0.454734	0.00536	98.82140
17	0.546389	0.02000	96.33960
18	0.390251	0.13126	66.36446
19	0.551137	0.01775	96.77939
20	0.563799	0.48013	14.84022
21	0.592805	0.51002	13.96436
22	0.47917	0.00699	98.54185

Table E.6: Case Study 3 Experiment 6 Results – 95.4% of the Load Supplied by CHP units

Customer at Load Point	AENS – Phase I (MWh/year)	AENS – Phase II (MWh/year)	Percentage Improvement in Reliability (%)
1	0.525035	0.00932	98.22402
2	0.579613	0.00902	98.44331
3	0.530853	0.00659	98.75866
4	0.56002	0.00706	98.73978
5	0.578274	0.00755	98.69441
6	0.468441	0.00589	98.74264
7	0.441398	0.00734	98.33759
8	1.00807	0.010097	98.99840
9	1.16248	0.00992	99.14654
10	0.553595	0.00718	98.70309
11	0.541097	0.00833	98.46141
12	0.54656	0.01098	97.99199
13	0.681466	0.01990	97.07977
14	0.635539	0.00995	98.43372
15	0.480154	0.00415	99.13674
16	0.454734	0.00490	98.92245
17	0.546389	0.01989	96.36047
18	0.390251	0.01301	96.66625
19	0.551137	0.01765	96.79753
20	0.563799	0.00712	98.73661
21	0.592805	0.48790	17.69638
22	0.47917	0.00695	98.55062

Table E.7: Case Study 3 Experiment 7 Results – 100% of the Load Supplied by CHP units

Customer at Load Point	AENS – Phase I (MWh/year)	AENS – Phase II (MWh/year)	Percentage Improvement in Reliability (%)
1	0.525035	0.00545	98.96187
2	0.579613	0.00515	99.11167
3	0.530853	0.00272	99.48831
4	0.56002	0.00318	99.43144
5	0.578274	0.00368	99.36427
6	0.468441	0.00202	99.56947
7	0.441398	0.00346	99.21515
8	1.00807	0.10054	99.00260
9	1.16248	0.00605	99.47980
10	0.553595	0.00331	99.40279
11	0.541097	0.00445	99.17731
12	0.54656	0.00710	98.70083
13	0.681466	0.01602	97.64855
14	0.635539	0.00608	99.04329
15	0.480154	0.00027	99.94333
16	0.454734	0.00103	99.77416
17	0.546389	0.01601	97.06986
18	0.390251	0.01262	96.76614
19	0.551137	0.01377	97.50073
20	0.563799	0.00325	99.42364
21	0.592805	0.00614	98.96382
22	0.47917	0.00307	99.35899

APPENDIX F

RESULTS OF CASE STUDY 4

The results obtained in case study 4 were discussed in section 5.5. Here the AENS values for all the customers obtained in each experiment are listed.

Table F.1: Case Study 4 Experiment 1 Results - 5% of the Load Supplied by CHP units

Customer at Load Point	AENS – Phase I (MWh/year)	AENS – Phase II (MWh/year)	Percentage Improvement in Reliability (%)
1	1.97346	1.97289	0.0289
2	2.06976	2.06912	0.0309
3	2.16683	2.16627	0.0258
4	2.34138	0.006739	99.7122
5	2.43805	2.43744	0.0250
6	1.93537	1.93489	0.0248
7	2.05265	2.05222	0.0209
8	3.74209	3.74102	0.0286
9	4.79239	4.79116	0.0257
10	2.08473	2.08412	0.0293
11	2.20231	2.20174	0.0259
12	1.89157	1.89096	0.0322
13	2.47258	2.47184	0.0299
14	2.49803	2.49736	0.0268
15	2.07551	2.07502	0.0236
16	1.75267	1.75219	0.0274
17	1.70254	1.70194	0.0352
18	1.76342	1.76304	0.0215
19	1.87051	1.86992	0.0315
20	2.46231	2.46174	0.0231
21	2.53036	2.52975	0.0241
22	2.04461	2.0438	0.0396

Table F.2: Case Study 4 Experiment 2 Results - 15% of the Load Supplied by CHP units

Customer at Load Point	AENS – Phase I (MWh/year)	AENS – Phase II (MWh/year)	Percentage Improvement in Reliability (%)
1	1.97346	1.9715	0.0973
2	2.06976	2.0682	0.0744
3	2.16683	2.1650	0.0868
4	2.34138	2.3394	0.0829
5	2.43805	2.4370	0.0435
6	1.93537	1.9338	0.0832
7	2.05265	2.0512	0.0706
8	3.74209	0.0127	99.6606
9	4.79239	4.7899	0.0520
10	2.08473	2.0837	0.0494
11	2.20231	2.2008	0.0686
12	1.89157	0.0203	98.9273
13	2.47258	2.4701	0.1003
14	2.49803	2.4968	0.0492
15	2.07551	2.0739	0.0790
16	1.75267	0.0070	99.6006
17	1.70254	1.7010	0.0905
18	1.76342	1.7621	0.0726
19	1.87051	1.8685	0.1069
20	2.46231	2.4604	0.0764
21	2.53036	2.5289	0.0577
22	2.04461	2.0431	0.0739

Table F.3: Case Study 4 Experiment 3 Results - 25% of the Load Supplied by CHP units

Customer at Load Point	AENS – Phase I (MWh/year)	AENS – Phase II (MWh/year)	Percentage Improvement in Reliability (%)
1	1.97346	1.9703	0.1596
2	2.06976	0.0041	99.8032
3	2.16683	2.1638	0.1421
4	2.34138	2.3384	0.1273
5	2.43805	2.4347	0.1370
6	1.93537	1.9327	0.1359
7	2.05265	2.0503	0.1155
8	3.74209	0.0128	99.6574
9	4.79239	0.0095	99.8009
10	2.08473	2.0814	0.1583
11	2.20231	2.1992	0.1417
12	1.89157	1.8883	0.1755
13	2.47258	2.4690	0.1448
14	2.49803	2.4944	0.1461
15	2.07551	2.0728	0.1291
16	1.75267	1.7500	0.1501
17	1.70254	1.6993	0.1932
18	1.76342	0.0182	98.9656
19	1.87051	1.8672	0.1748
20	2.46231	2.4592	0.1251
21	2.53036	2.5270	0.1320
22	2.04461	2.0423	0.1130

Table F.4: Case Study 4 Experiment 4 Results - 50% of the Load Supplied by CHP units

Customer at Load Point	AENS – Phase I (MWh/year)	AENS – Phase II (MWh/year)	Percentage Improvement in Reliability (%)
1	1.97346	1.9674	0.3076
2	2.06976	2.0643	0.2638
3	2.16683	0.0174	99.1954
4	2.34138	2.3373	0.1743
5	2.43805	0.0087	99.6442
6	1.93537	1.9303	0.2620
7	2.05265	2.0481	0.2226
8	3.74209	0.0108	99.7102
9	4.79239	0.0081	99.8313
10	2.08473	0.0049	99.7629
11	2.20231	2.1963	0.2733
12	1.89157	0.0190	98.9976
13	2.47258	2.4647	0.3175
14	2.49803	0.0135	99.4606
15	2.07551	0.0160	99.2273
16	1.75267	0.0074	99.5758
17	1.70254	1.6988	0.2197
18	1.76342	0.0203	98.8506
19	1.87051	1.8663	0.2251
20	2.46231	2.4564	0.2412
21	2.53036	2.5239	0.2537
22	2.04461	2.0356	0.4407

REFERENCES

- [1] T. Ackerman, G. Anderson and L. Soder, "Distributed generation: A definition", *Electrical Power Systems, Res.*, vol.57, pp. 195-204, 2004.
- [2] "Embedded Generation", IEE Power Energy Series 31, Nick Jenkins, Ron Allan, Peter Crossley, David Kirschen, Goran Strbac.
- [3] F.V.Edwards, G.J.Dudgeon, J.R.McDonald and W.E.Leithead, "Dynamics of distribution networks with distributed generation", *Proc. IEEE Power Eng. Soc. Summer Meeting*, pp. 1032-1037, 2000.
- [4] Dixon, G.F.L., Hammersley, H., "Reliability and its Cost on Distribution Systems". *International Conference on Reliability of Power Supply Systems, 1977, IEE Conference Publication, No.148.*
- [5] Roy Billinton, Ronald Allan, *Reliability Assessment of Large Electric Power Systems*, Boston/Dordrecht/Lancaster: Kluwer, 1988.
- [6] Roy Billinton, Wenyuan Li, *Reliability Assessment of Electric Power Systems Using Monte Carlo Simulations*, New York: Plenum, 1994.
- [7] Y.G.Hegazy, M.M.A.Salama and A.Y.Chikhani, "Adequacy assessment of distributed generation systems using Monte Carlo Simulation", *IEEE Transactions of Power Systems* Vol. 18, Feb. 2003, pp.141-143.
- [8] H. Lee. Willis, Walter G. Scott, *Distributed Power Generation*, New York: Basel, 2000.
- [9] IEEE Committee Report, "IEEE Reliability Test System", *IEEE Trans.*, PAS-98, 1979, pp.2047-2054.
- [10] R.N. Allan, R. Billinton, I. Sjarief, L. Goel, K. S. So, "A Reliability Test System for Educational Purposes- Basic Distribution Data and Results", *Assessment of Large Electric Power Systems* IEEE Trans., on Power Sys, Vol. 6, No. 2, May 1991.
- [11] "Reliability Evaluation of Power Systems", Roy Billinton, Ronald N. Allan, PLENUM PRESS, 2nd Edition.
- [12] "Reliability Assessment of Electrical Power Systems Using Monte Carlo Methods", Roy Billinton, Wenyuan Li, PLENUM PRESS.
- [13] Giuseppe Calabrese, "Generating Reserve Capacity Determined by the Probability Method", *AIEE Trans.*, vol. 66, pp. 1439-1450, Sept 1947.
- [14] Tejal Kanitkar, "Reliability Assessment of Distributed Generation Systems Using

Monte Carlo Simulation", Masters Thesis, Dept. of Mechanical and Industrial Engineering, Univ. of Massachusetts, Amherst, 2006.

- [15] IEEE Committee Report, 'Bibliography on the application of probability method in power system reliability evaluation', IEEE Trans. On Power Apparatus and Systems, PAS-91 (1972), pp. 649-60.
- [16] Mark Gerrish, "Reliability issues in Combined Heat and Power", Masters Thesis, Dept. of Mechanical and Industrial Engineering,, Univ. of Massachusetts Amherst, 2006.
- [17] "Monte Carlo Methods in Statistical Physics", Mark E. J. Newman, G. T. Barkema, 1999.